

TECHNICAL MANUAL

**GENERAL SUPPORT
MAINTENANCE MANUAL**

| |
|--------------------------------------|
| EQUIPMENT DATA PAGE 1-3 |
| PERFORMANCE TESTS PAGE 2-1 |
| TROUBLESHOOTING PAGE 2-34 |
| ALINEMENT PAGE 2-39 |
| MAINTENANCE PAGE 2-59 |

**TEST SET, RECEIVER
AN/ARM-186
(NSN 6625-00-557-1168)**



5 SAFETY STEPS TO FOLLOW IF SOMEONE IS THE VICTIM OF ELECTRICAL SHOCK

1 DO NOT TRY TO PULL OR GRAB THE INDIVIDUAL

2 IF POSSIBLE, TURN OFF THE ELECTRICAL POWER

3 IF YOU CANNOT TURN OFF THE ELECTRICAL POWER, PULL, PUSH, OR LIFT THE PERSON TO SAFETY USING A WOODEN POLE OR A ROPE OR SOME OTHER INSULATING MATERIAL

4 SEND FOR HELP AS SOON AS POSSIBLE

5 AFTER THE INJURED PERSON IS FREE OF CONTACT WITH THE SOURCE OF ELECTRICAL SHOCK, MOVE THE PERSON A SHORT DISTANCE AWAY AND IMMEDIATELY START ARTIFICIAL RESUSCITATION

WARNING

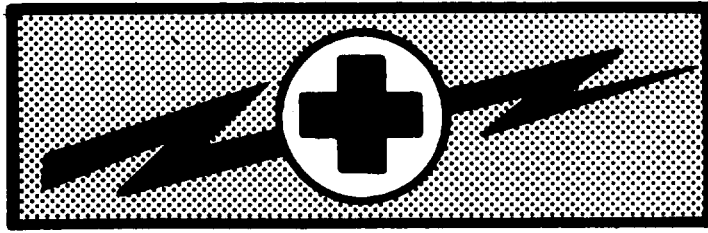

WARNING

HIGH VOLTAGE

IS USED IN THE OPERATION OF THIS EQUIPMENT

DEATH ON CONTACT

MAY RESULT IF PERSONNEL FAIL TO OBSERVE SAFETY PRECAUTIONS

Never work on electronic equipment unless there is another person nearby who is familiar with the operation and hazards of the equipment and who is competent in administering first aid. When the technician is aided by operators, he must warn them about dangerous areas.

Whenever possible, the power supply to the equipment must be shut off before beginning work on the equipment. Take particular care to ground every capacitor likely to hold a dangerous potential. When working inside the equipment, after the power has been turned off, always ground every part before touching it.

Be careful not to contact high-voltage connections of 115 volt ac input connections when installing or operating this equipment.

Whenever the nature of the operation permits, keep one hand away from the equipment to reduce the hazard of current flowing through vital organs of the body.

WARNING Do not be misled by the term "low voltage". Potentials as low as 50 volts may cause death under adverse conditions.

For Artificial Respiration, refer to FM 21-11.

WARNING

HIGH VOLTAGE

is used in the operation of this equipment.

DEATH ON CONTACT

may result if personnel fail to observe safety precautions.

Never work on electronic equipment unless there is another person nearby who is familiar with the operation and hazards of the equipment and who is competent in administering first aid. When the technician is aided by operators, he must warn them about dangerous areas.

Be careful not to contact high-voltage connections of 115 vac input connections when installing or operating this equipment.

Dangerous potentials exist at several points throughout this equipment, when the equipment is operated with the case removed. Do not touch exposed connections or components. Some transistors have voltages present on their cases. Disconnect power before cleaning the equipment or replacing parts.

Whenever the nature of the operation permits, keep one hand away from the equipment to reduce the hazard of current flowing through vital organs of the body.

For artificial respiration, refer to FM 21-11.

WARNING

TRICHLOROTRIFLUOROETHANE

Fumes of TRICHLOROTRIFLUOROETHANE are poisonous. Provide adequate ventilation whenever you use TRICHLOROTRIFLUOROETHAN E. Do not use solvent near heat or open flame. TRICHLOROTRIFLUOROETHAN E will not burn, but heat changes the gas into poisonous, irritating fumes. DO NOT breathe the fumes or vapors. TRICHLOROTRIFLUOROETHANE dissolves natural skin oils. DO NOT get the solvent on your skin. Use gloves, sleeves, and an apron which the solvent cannot penetrate. If the solvent is taken internally, consult a physician immediately.

Technical Manual

No. 11-6625-2976-40

HEADQUARTERS
DEPARTMENT OF THE ARMY
Washington, DC, 9 July 1985

General Support
Maintenance Manual

TEST SET, RECEIVER
AN/ARM-186
(NSN 6625-00-557-1168)

REPORTING ERRORS AND RECOMMENDING IMPROVEMENTS

You can help improve this manual. If you find any mistakes or if you know of a way to improve the procedures, please let us know. Mail your letter, DA Form 2028 (Recommended Changes to Publications and Blank Forms), or DA Form 202&2 located in the back of this manual direct to: Commander, US Army Communications-Electronics Command and Fort Monmouth, ATTN: AMSEL-ME-MP, Fort Monmouth, New Jersey 07703-5007. A reply will be furnished direct to you.

| | Page |
|---|------------------------------|
| HOW TO USE THIS MANUAL..... | i i |
| CHAPTER 1 INTRODUCTION | 1-1 |
| Section I General Information | 1-1 |
| II Equipment Description and Data | 1-3 |
| III Principles of Operation | 1-5 |
| CHAPTER 2 MAINTENANCE | 2-1 |
| Section I Repair Parts, Special Tools, TMDE, and Support Equipment | 2-1 |
| II Performance Test Procedures | 2-1 |
| III Troubleshooting | 2-34 |
| IV Alinement Procedures | 2-39 |
| V Maintenance Procedures | 2-59 |
| APPENDIX A REFERENCES | A-1 |
| B EXPENDABLE SUPPLIES AND MATERIALS LIST | B-1 |
| GLOSSARY | Glossary 1 |
| INDEX | Index 1 |
| FOLDOUTS | Located in back of manual |

* This manual together with TM 11-6625-2976-12, 17 September 1984, and TM 11-6625-2976-24P, 26 July 1984, supersedes TM 11-6625-2976-14&P, 20 January 1981.

HOW TO USE THIS MANUAL

This manual is designed to help you maintain Test Set, Receiver AN/ARM-186. Maintenance of the test set is limited to procedures that do not require it to operate as part of a specific communications system.

The boxed entries on the front cover are provided for quick reference to important information. There is also an alphabetical index in the rear of the book to help locate specific information.

Measurements in this manual are given in both US standard and metric units.

Read all preliminary information found at the beginning of each procedure. It contains important information which must be followed to perform tasks correctly.

Warning pages are located in the front of this manual. You should learn the warnings before doing maintenance on the equipment.

Paragraphs in this manual are numbered by chapter and order of appearance within a chapter. A subject index appears at the beginning of each chapter, breaking the chapter into sections. A more specific subject index is located at the beginning of each section to help you find the exact paragraph you are looking for.

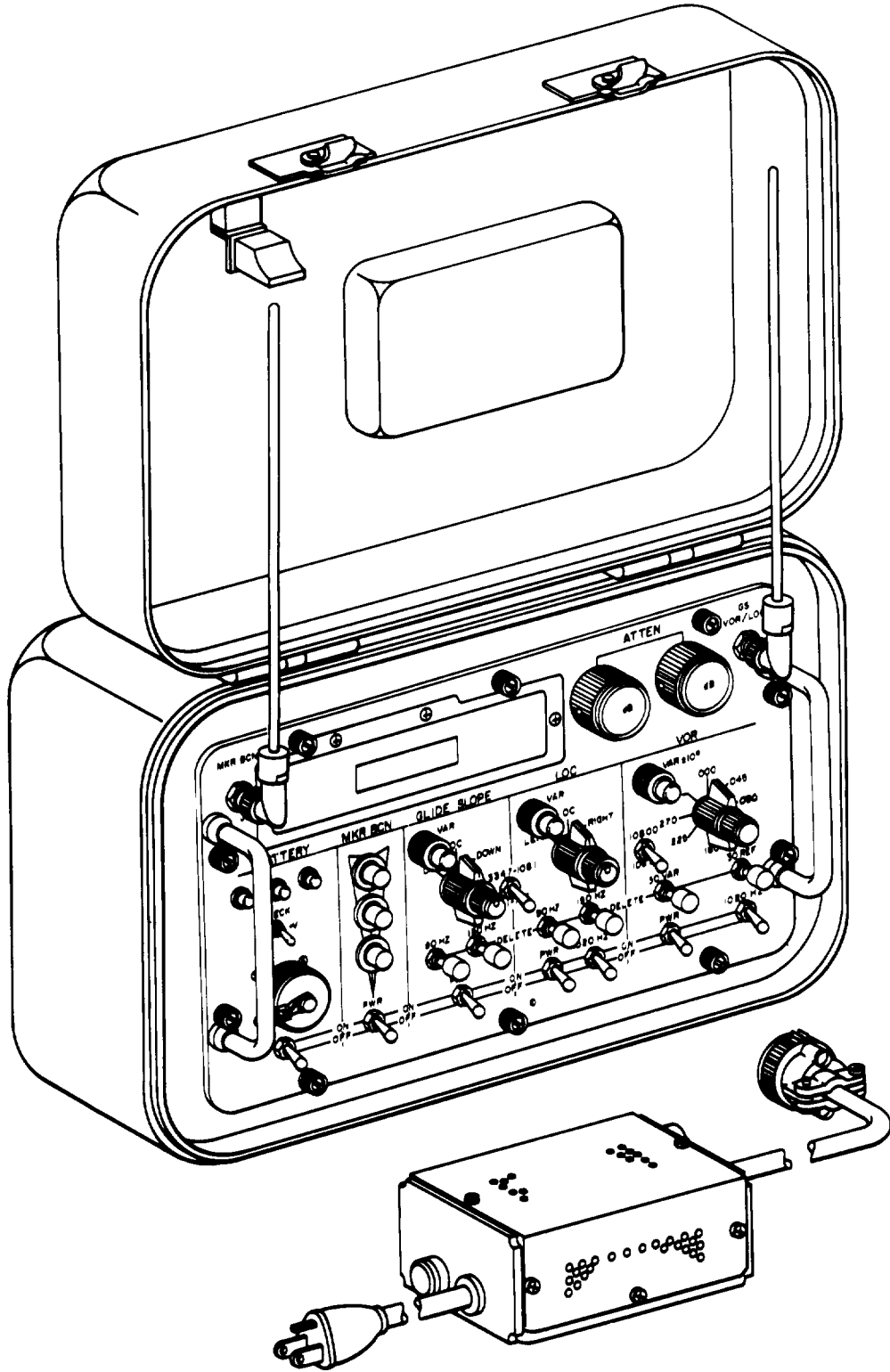

EL9MA002

TEST SET, RECEIVER AN/ARM-186

CHAPTER 1
INTRODUCTION

| Subject | Section | Page |
|--|---------|------|
| General Information | I | 1-1 |
| Equipment Description and Data | II | 1-3 |
| Principles of Operation | III | 1-5 |

OVERVIEW

This chapter will familiarize you with Test Set, Receiver AN/ARM-188, It contains general and specific information about the equipment and references to pertinent forms and publications.

Section I GENERAL INFORMATION

| Subject | Para | Page |
|---|------|------|
| Scope | 1-1 | 1-1 |
| Consolidated index of Army Publications and Blank Forms | 1-2 | 1-1 |
| Maintenance Forms, Records, and Reports | 1-3 | 1-1 |
| Destruction of Army Electronics Materiel to Prevent Enemy Use | 1-4 | 1-2 |
| Calibration | 1-5 | 1-2 |
| Administrative Storage | 1-8 | 1-2 |
| Reporting Equipment Improvement Recommendations (EIR) | 1-7 | 1-2 |
| Nomenclature Cross-Reference List | 1-8 | 1-2 |

1-1. SCOPE.

Type of Manual: General support maintenance manual.

Equipment Name and Model Number: Test Set, Receiver AN/ARM-188 (Collins 972Q-4).

Purpose of Equipment: To generate both rf and audio signals for use in cockpit checks of an aircraft's VOR, localizer, glide slope, and marker beacon receivers,

1-2. CONSOLIDATED INDEX OF ARMY PUBLICATIONS AND BLANK FORMS.

Refer to the latest issue of DA Pam 310-1 to determine whether there are new editions, changes, or additional publications pertaining to the equipment.

1-3. MAINTENANCE FORMS, RECORDS, AND REPORTS.

REPORTS OF MAINTENANCE AND UNSATISFACTORY EQUIPMENT

Department of the Army forms and procedures used for equipment maintenance will be those prescribed by DA Pam 738.750, as contained in Maintenance Management Update.

1-3. MAINTENANCE FORMS, RECORDS, AND REPORTS. (CONT)

REPORTS OF PACKAGING AND HANDLING DEFICIENCIES

Fill out and forward SF 364 (Report of Discrepancy (ROD)) as prescribed in AR 735-11-2/DLAR 4140.55/NAVMATINST 4355.73A/AFR 400-54/MCO 4430.3F.

DISCREPANCY IN SHIPMENT REPORT (DISREP) (SF 361)

Fill out and forward Discrepancy in Shipment Report (DISREP) (SF 361) as prescribed in AR 55-38/NAVSUPINST 4610.33C/AFR 75-18/MCO P4610.19D/DLAR 4500.15.

1-4. DESTRUCTION OF ARMY ELECTRONICS MATERIEL TO PREVENT ENEMY USE.

Destruction of Army electronics materiel to prevent enemy use shall be in accordance with TM 750-244-2.

1-5. Calibration.

Calibration procedures for Test Set, Receiver AN/ARM-186 are covered in TB 9-8825-2052-35.

1-6. ADMINISTRATIVE STORAGE.

Preventive maintenance, in accordance with the PMCS charts in TM 118625-2976-12, will be performed prior to administrative storage of equipment issued to and used by Army activities. When removing the equipment from administrative storage, PMCS shall be performed to ensure operational readiness.

Administrative storage of equipment shall be done in accordance with TM 740-90-1. Disassembly and repacking of equipment for shipment, limited storage, or intermediate storage are covered in TM 11-8625-2976-12.

1-7. REPORTING EQUIPMENT IMPROVEMENT RECOMMENDATIONS (EIR).

If your Test Set, Receiver AN/ARM-186 needs improvement, let us know. Send us an EIR. You, the user, are the only one who can tell us what you don't like about your equipment. Let us know why you don't like the design. Put it on an SF 368 (Quality Deficiency Report). Mail it to Commander, US Army Communications-Electronics Command and Fort Monmouth, ATTN: AMSEL-ME-MP, Fort Monmouth, New Jersey 07703-5007. We'll send you a reply.

1-8. NOMENCLATURE CROSS-REFERENCE LIST.

This list contains common names used throughout this manual in place of official nomenclature.

| COMMON NAME | OFFICIAL NOMENCLATURE |
|-------------|-------------------------------|
| test set | Test Set, Receiver AN/ARM-186 |

Section II EQUIPMENT DESCRIPTION AND DATA

| Subject | Para | Page |
|---|------|------|
| Equipment Characteristics, Capabilities, and Features | 1-9 | 1-3 |
| Location and Description of Major Components | 1-10 | 1-3 |
| Equipment Data | 1-11 | 1-3 |
| Safety, Care, and Handling | 1-12 | 1-5 |

1-9. EQUIPMENT CHARACTERISTICS, CAPABILITIES, AND FEATURES.

The characteristics, capabilities, and features of the test set are covered in TM 11-6625-2976-12.

1-10. LOCATION AND DESCRIPTION OF MAJOR COMPONENTS.

Location of major components is shown on FO-1.

RF Modules A1 through A5. Attached to A8 mounting plate which is located at rear of electronics component assembly. Generate and process rf signals according to control settings on front panel assembly,

A7 Combiner Assembly. Attached to upper corner of A8 mounting plate and is used for impedance matching and combining rf signals.

Circuit Card Assembly A6. Located between A8 mounting plate and front panel. A6 generates and processes modulated and control signals selected at front panel,

Front Panel Assembly. Contains necessary switches and lamps that control operation of test set.

1-11. EQUIPMENT DATA.

TM 11-6625-2976-12 contains a complete list of the test set's physical and environmental specifications and those electronic specifications needed to support lower level maintenance. The following list contains additional electronic data needed for general support maintenance.

| CHARACTERISTIC | SPECIFICATION |
|----------------|---------------|
|----------------|---------------|

VOR

Amplitude modulation

| | |
|---------------------------|----------------|
| modulation depth | 30 ±3% |
| 30 Hz variable distortion | Less than 5% |
| 9960 Hz distortion | Less than 3°/0 |

VOR audio tones

| | |
|--------------------|------------------|
| Frequency accuracy | ±0.01% |
| 9960 Hz deviation | 480 ± 30 Hz peak |

1-11. EQUIPMENT DATA. (CONT)

| CHARACTERISTIC | SPECIFICATION |
|---|-----------------------------------|
| VOR - Continued | |
| 1020 Hz Identification tone Amplitude modulation Frequency accuracy Distortion | 10 ± 5% ±2.5% Less than 10% |
| LOC/GS | |
| Amplitude modulation Distortion | Less than 5% |
| Audio tone Frequencies Frequency accuracy | 90 and 150 Hz 0.01% |
| 1020 Hz LOC identification tone Amplitude modulation Frequency accuracy Distortion | 10 ±5% ±2.5% Less than 10% |
| MARKER BEACON | |
| Amplitude modulation Modulation depth Distortion | 95 ±5% Less than 15% |
| Audio tone Frequencies Frequency accuracy | 400,1300, and 3000 Hz ±2% |

1-12. SAFETY, CARE, AND HANDLING.

Obey all Warnings, Cautions, and Notes in this manual. Failure to follow directions could result in serious injury to personnel and/or damage to equipment.

Be careful not to drop the test set. Personal injury and damage to equipment could result.

Before operating the test set, make sure batteries are removed.

Before removing test set from its case, open the PRESSURE EQUALIZER valve (located on the bottom of the case) to allow case atmosphere and pressure to balance.

When moving or operating the test set, take care to keep your eyes from coming in contact with the tips of extended test set antennas.

NOTE

Aii maintenance procedures must be performed using external 8 vdc sources. If a source is used besides the companion battery charger, the ramp test set batteries must be removed or battery damage will result.

Section III PRINCIPLES OF OPERATION

| Subject | Para | Page |
|-------------------------------------|------|------|
| General..... | 1-13 | 1-5 |
| DC Power Distribution..... | 1-14 | 1-7 |
| Battery Check Capability..... | 1-15 | 1-8 |
| Modulating Circuits..... | 1-16 | 1-9 |
| RF Modules and RF Distribution..... | 1-17 | 1-14 |
| VAR Lamp Flasher Capability..... | 1-18 | 1-15 |
| Battery Charger Function..... | 1-19 | 1-16 |

1-13. GENERAL.

The test set is a compact, portable, battery-operated uhf/vhf signal generator. Test set transmissions, which simulate VOR, GS, LOC, and MB ground station signals, are used to examine the response of aircraft navigational systems.

This section covers the test set's electronic principles of operation. A general overview of major components and their interrelationships is followed by details of power supply, modulation, and rf signal flow application. This is accomplished by discussing the relationship of major components (power source, circuit card assembly, and rf modules) to front panel controls.

At the general support level of maintenance, electronic components within the test set's A6 circuit card and rf modules are not replaced. Because of this maintenance approach, this section does not discuss performance of specific components (diodes, transistors, etc). Instead, the text explains how each subassembly contributes to the overall operation of the test set.

1-13. GENERAL. (CONT)

OVERALL OPERATION

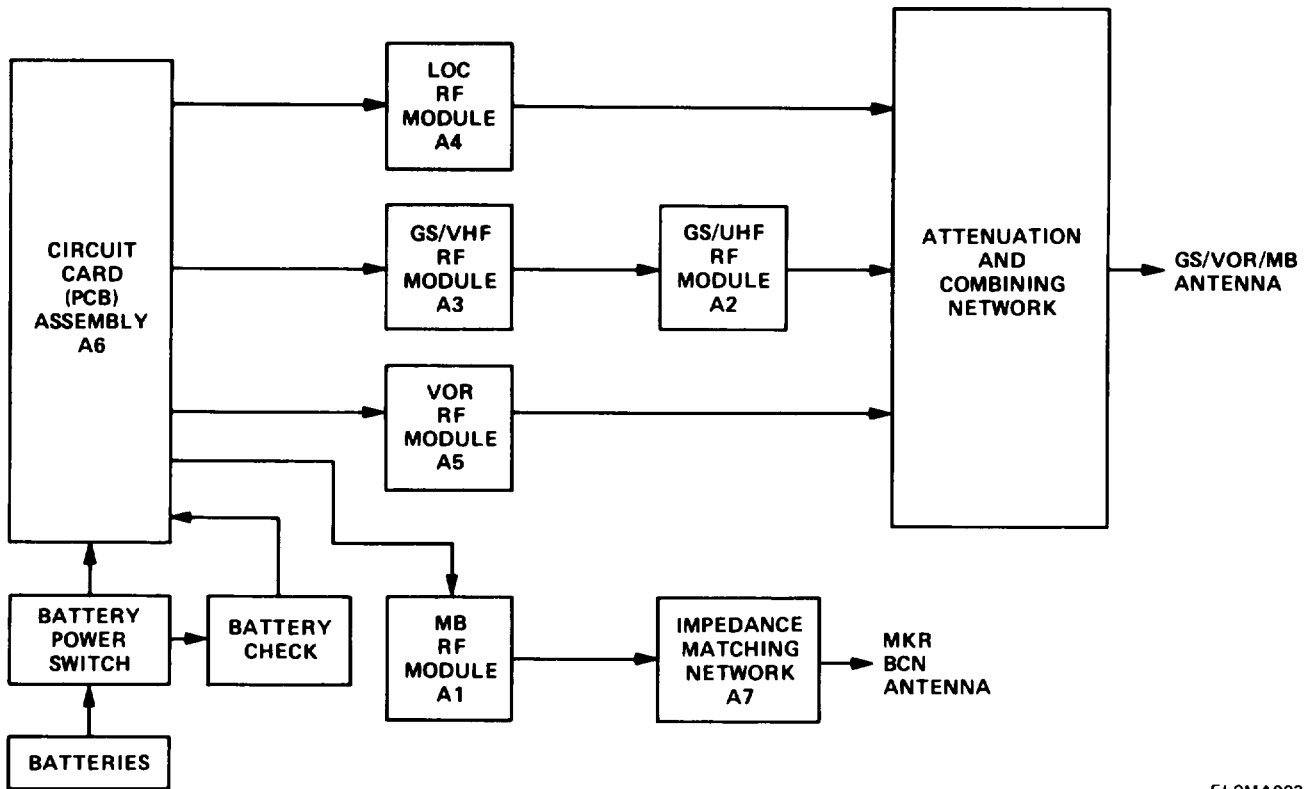

EL9MA003

Two rechargeable internal batteries supply operating voltage to test set circuits. The battery check circuit, when activated, indicates whether or not batteries need recharging. The front panel controls select the test set's operational mode by:

1. Providing a path for operating voltage through circuit card assembly A6 to selected rf modules.
2. Controlling the input frequencies provided by circuit card assembly A6 for appropriate rf modules.

The logic and control circuitry in circuit card assembly A6 directs and applies operating voltage to rf modules selected by the control panel switch settings. This circuitry also generates modulation signals used by rf modules to develop appropriate rf frequencies.

The test set contains five rf modules, as follows:

1. MB RF Module A1
2. GS/UHF RF Module A2
3. GS/VHF RF Module A3
4. LOC RF Module A4
5. VOR RF Module A5

1-13. GENERAL. (CONT)

The rf modules receive operating voltage and modulating signals from their respective portions of the circuit card assembly. Fixed or variable modulating signals are applied to the LOC, GS, or VOR modules. Fixed modulation only is applied to the MB module. The rf modules then provide carriers for the modulating signals.

The modulated rf output signals from the LOC, GS, and VOR modules are applied to the GS/VOR/LOC antenna through an attenuation and combining network. The attenuators can be adjusted by controls on the front panel to provide 0 to 110 db of attenuation. The MB rf output signal is fed through an impedance matching network to the separate MKR BCN antenna.

The fixed or variable rf outputs of the GS/VOR/LOC antenna provide on-course or deviated-course GS, VOR, or LOC indications for aircraft navigational systems. The fixed rf outputs of the MKR BCN antenna provide outer marker, middle marker, or inner marker signals.

1-14. DC POWER DISTRIBUTION.

Refer to FO-3 while reading the following text.

Two 8-volt batteries provide dc power for all test set circuits. The batteries are series connected with a common ground to allow + 8 volts and -8 volts application.

Dc power is applied from the batteries directly to circuit card (PCB) assembly A6 at J19. J19 connects directly to J20, which makes battery power available at main power switch S2. S2 controls power to all circuits in the test set.

In addition to S2, each modulating circuit and its accompanying rf module has its own power switch. These front panel switches make operating voltage available for each individual test set function. When S2 is in the ON position, dc power is available at all front panel power switches (S6, S10, S15, and S21). When any of these switches is also in the ON position, operating voltage is applied in the following manner:

1. Through the controls in selected front panel section and J20 to appropriate circuit card assembly modulating circuits.
2. Through J20 and by direct circuit card path through the P1 connector to the appropriate rf module. (The P1 connections are illustrated on FO-2 and FO-3.)

1-15. BATTERY CHECK CAPABILITY.

An Internal voltage check circuit provides an instantaneous test for test set batteries. As a result of this test, front panel lamps will indicate whether or not batteries need recharging. The battery check is independent of other test set functions and maybe initiated at any time, as long as power (PWR) switch S2 is in ON position.

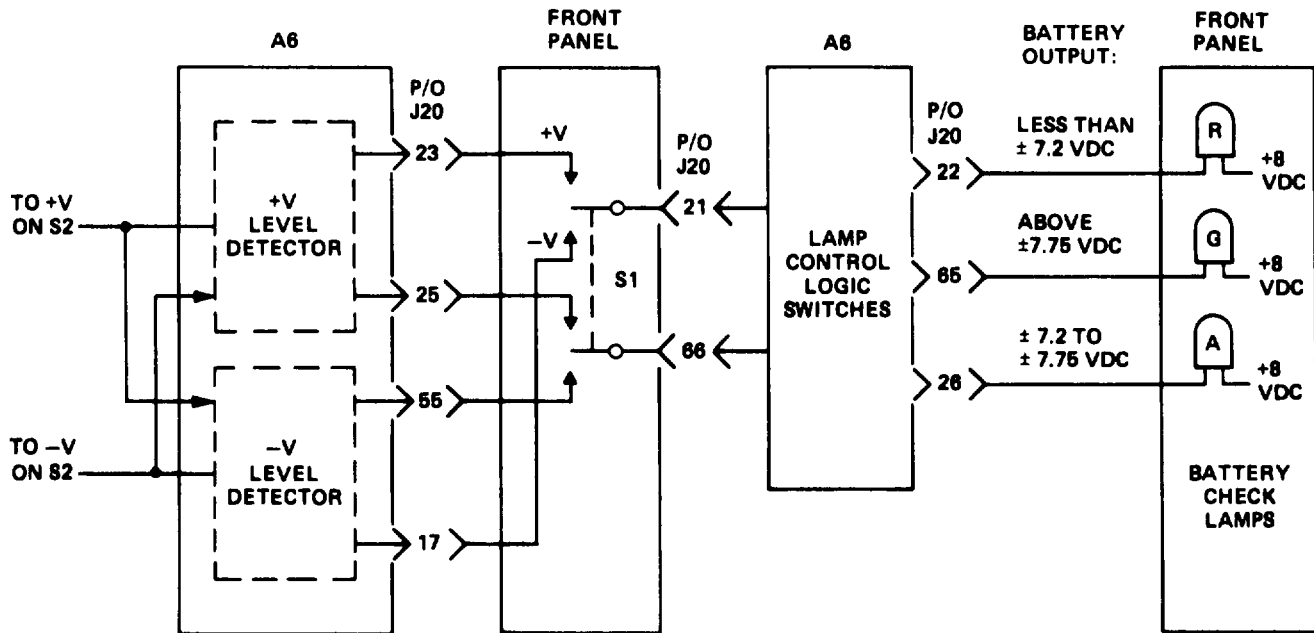

EL9MA004

Positive or negative battery output voltages can be checked by holding front panel momentarily on BATTERY CHECK switch S1 in + V or -V position. Depending on switch position, either + V level detector or -V level detector monitors the respective battery output, and the path between appropriate level detector and lamp control logic switch circuitry is completed.

NOTE

The level detectors and lamp control logic switch circuitry are located on circuit card (PCB) assembly A6.

Based on battery output voltage, level detector turns on one of three lamp control logic switches. This completes a path to front panel battery check lamps.

If level detector indicates that battery output is above ± 7.75 vdc, a lamp control logic switch will turn on green lamp. If it indicates an output of between ± 7.2 and ± 7.75 vdc, another switch will turn on the amber lamp. If the level detector indication is less than ± 7.2 vdc, a third switch will turn on the red lamp.

1-15. BATTERY CHECK CAPABILITY. (CONT)

Sometimes more than one lamp will light when the battery is checked. This indicates that the + V and -V batteries are at different voltage levels.

1-16. MODULATING CIRCUITS.

The circuit card assembly A6 modulating circuits generate modulating and control signals selected by the front panel controls and apply them to LOC, GS, VOR, and MB rf modules. The fundamental frequencies used to develop these signals come from two sources:

1. The 3.932 MHz crystal oscillator and frequency divider,
2. The MB vco.

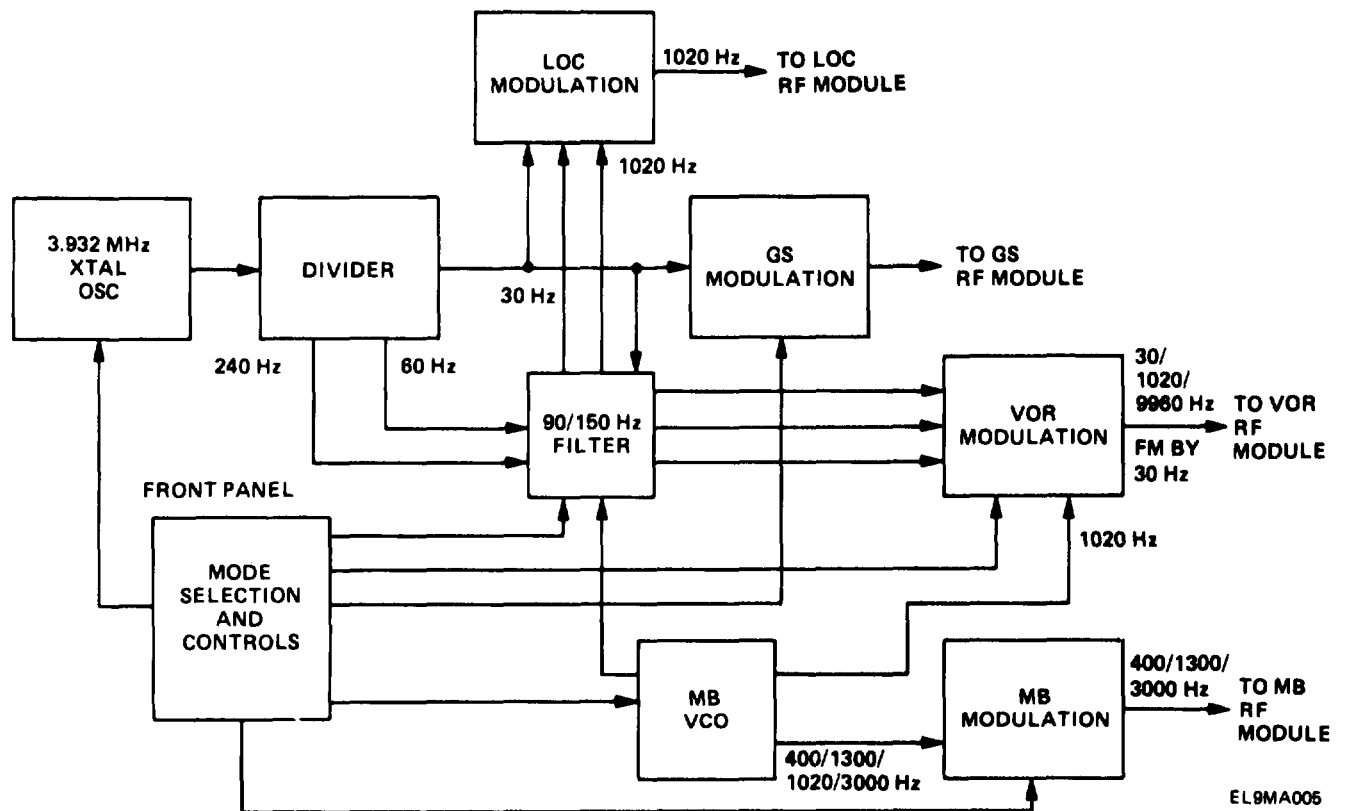

The 3,932 MHz crystal oscillator and frequency divider, activated when S2 is placed in the ON position, generate three fundamental frequencies: 30,60, and 240 Hz. The 30 Hz fundamental frequency is applied to GS, LOC, and VOR modulating circuits. The GS and LOC modulating circuits use this frequency to develop 90 and 150 Hz GS and LOC modulating frequencies, which are applied to GS and LOC rf modules, in the VOR modulating circuit, 30 and 240 Hz fundamental frequencies work together to produce signals corresponding to the front panel VOR bearing select switch setting, The VOR modulating circuit uses the 60 Hz fundamental frequency as a reference signal to produce the 9960 Hz.

The MB vco provides the 1020 Hz modulating frequency for VOR and LOC modulating circuits and develop the 400, 1300, and 3000 Hz signals needed for MB modulation.

1-16. MODULATING CIRCUITS. (CONT)

LOC/GS MODULATION

Refer to FO-5 while reading the following text.

Operating voltage is applied to LOC modulating circuits in circuit card assembly and LOC rf module A4 by closing front panel switches S2, S16, S12, and S15. Operating voltage is applied to GS modulating circuits in circuit card assembly and GS rf module A3 by closing switches S2, S10, and S12.

Crystal oscillator Y1 generates a 3.932 MHz signal and applies it to a frequency divider whose output is 30 Hz. The 30 Hz signal is applied through a limiter to limit the gain of the signal. From the limiter, 30 Hz is applied to both 90 Hz and 150 Hz band pass filter circuits. The 90 Hz band pass filter circuitry consists of amplifiers which accept and amplify third order harmonics to produce the 90 Hz signal. Amplifiers in the 150 Hz band pass filter circuitry accept and amplify fifth order harmonics to produce the 150 Hz signal. Test points J4 and J3 are provided to check for 90 Hz and 150 Hz LOC and GS modulating signals. These signals are applied from the band pass filter circuitry through the normally closed front panel 90 Hz and 150 Hz DELETE switches to LOC or GS mode selection circuits in the circuit card assembly. Depressing either the 90 Hz or 150 Hz DELETE switches opens the respective signal path and removes the signal from the circuitry.

Mode Selection

The LOC and GS mode selection circuits are controlled by their corresponding front panel LOC and GS controls.

LOC Mode Selection. In addition to LOC 90 Hz and 150 HZ DELETE, test set provides the following LOC operational modes:

1. On-course (LOC OC)
2. Variable (LOC VARIABLE)
3. Left/right (LOC LEFT/RIGHT)
4. 1020 Hz modulation

When the on-course mode is selected by the front panel LOC LEFT/OC/RIGHT switch, the circuit card assembly will apply the signal through corresponding circuitry while inhibiting the other modes. The on-course mix of 90 Hz and 150 Hz is applied through the LOC OC amplifier and LOC OC/VAR select switch to the LOC output amplifier where the signal is amplified and applied to LOC rf module A4. Test point J2 is provided to check the output modulating signal.

Setting the LOC on-course switch to LEFT or RIGHT allows either 90 Hz or 150 Hz signal to be amplified by the LOC output amp. In this manner, the appropriate LOC LEFT or RIGHT conditions are transmitted.

Selection of variable mode is accomplished by pressing the LOC VAR lamp/switch once causing the lamp to blink. The LOC VAR switch then overrides the LEFT/OC/RIGHT switch selection and controls the signal path. The amplitudes of the 90 Hz and 150 Hz modulating signals are adjusted by front panel variable control R2 before passing through the LOC VAR circuits and LOC output amp to rf module A4. Pressing the VAR lamp/switch a second time disables the VAR mode and returns operational control to the LEFT/OC/RIGHT switch.

Closing the front panel LOC 1020 HZ switch enables the MB vco to apply 1020 Hz audio signal through the LOC output amp to amplitude modulate the composite LOC rf output signal.

GS Mode Selection. In addition to the GS 90 Hz and 150 Hz DELETE modes, test set provides the following GS operational modes:

1. On-course (GS OC)
2. Variable (GSVAR)
3. Up/down (GS UP/DOWN)

The GS on-course and variable modes function much the same way as corresponding LOC modes. The 90 Hz and 150 Hz GS signals are directed by the appropriate GS front panel switches through the circuit card assembly's GS OC or GS VAR and the GS output amp to GS/UHF rf module A2.

The GS up and down modes function in the same manner as LOC left and right modes. The 150 Hz (up) or 90 Hz (down) signal is directed by the appropriate GS UP/DOWN front panel switch through the circuit card assembly's GS UP/DOWN SELECT and GS output amp to GS/UHF rf module A2. Test point J1 provides a check of the GS output modulated signals.

VOR MODULATION

Refer to FO-6 while reading the text in this section.

Operating voltage is applied to the VOR modulating circuits in the circuit card assembly and VOR rf module A5 by closing front panel switches S2, S18, S22 and S21. See paragraph 1-14 for a discussion of DC Power Distribution.

The VOR modulating circuits use all three frequencies generated by the 3.932 crystal oscillator and frequency divider. The 30 Hz signal is applied to a phase shift network and phase (bearing) select switches in the circuit card assembly. The 240 Hz signal provides a clock pulse for the phase shift network, which uses this signal to produce seven 30 Hz phase difference signals. These signals correspond to 45 through 315 degrees in 45-degree increments.

Eight signals, seven produced by the phase shift network and 000 in-phase 30 Hz signal, are applied to the phase (bearing) select switches. The bearing signal selected by the front panel VOR bearing select switch (S17) determines which one of these signals will be activated. The 180-degree bearing signal is taken as the reference 30 Hz and applied to one path through the 30 Hz VAR/REF DELETE switch.

The circuit card assembly variable/reference delete switch is controlled by three front panel switches:

1. VAR $\pm 10^\circ$ switch S25
2. 30 VAR DELETE switch S19
3. 30 REF DELETE switch S20

1-16. MODULATING CIRCUITS.(CONT)

VOR MODULATION (CONT)

Both delete switches are normally closed. In its normal or unlit position, the VAR $\pm 10^\circ$ switch provides the paths through the circuit card assembly variable/reference delete and NORMAL/VAR select switches for the reference and front panel bearing select switch-selected 30 Hz signals.

Switches in Normal Mode

With the front panel VOR 30 REF, 30 VAR, switches in their normal positions, the 30 Hz reference signal is applied through a 30 Hz reference and band pass filter and phase shift network to the loop summing amp. Meanwhile, the switch-selected (bearing) 30 Hz signal is applied through another 30 Hz band pass filter, the normal portion of the 30 Hz normal/variable select and a 30 Hz variable phase shift network. The output of the phase shift network and a developed 9960 Hz signal from the 9960 Hz vco are applied to the VOR composite amp for distribution to VOR rf module A5. The VOR composite amp also will apply the 1020 Hz signal generated by the MB vco to VOR rf module A5 when 1020 Hz switch S22 is closed.

The 9960 Hz signal applied to the VOR composite amp is generated by a 9960 Hz vco. The 30 Hz signal from the loop summing amp frequency modulates the 9960 Hz signal.

The 9960 Hz vco is kept on frequency by a phase locked loop correction network, which uses the 60 Hz fundamental frequency generated by the 3.932 MHz crystal oscillator and frequency divider as a phase reference for the vco output. That is, the correction network keeps the vco output in phase with the 60 Hz reference signal. The output of the phase locked loop correction network is applied to the 9960 Hz vco through the loop summing amp.

VAR $\pm 10^\circ$ LAMP/SWITCH VARIABLE MODE

Pressing the VAR $\pm 10^\circ$ lamp/switch enables the VOR variable mode of operation. In the variable mode, the front panel bearing select switch-selected 30 Hz signal is applied through variable control R3 (FO-3) to the 30 Hz VARIABLE PHASE SHIFT NETWORK. Variable control R3 is used to vary the phase of the select signal $\pm 10^\circ$ in bearing.

1-16. MODULATING CIRCUITS. (CONT)**Delete Switch Open Mode**

Pressing front panel 30 VAR DELETE switch S19 or 30 REF DELETE switch S20 opens (removes) the 30 Hz variable or the 30 Hz reference signal from the VOR composite signal.

MB MODULATION AND VOR/LOC 1020 HZ SIGNAL

Refer to (FO-6) while reading the text in this section.

Operating voltage is applied to the MB modulating circuits in the circuit card assembly and MB rf module A1 through front panel PWR switches S6 and S2. MB PWR switch S6 also determines whether the 1020 Hz signal is available to LOC/VOR modulating circuits or 400, 1300, and 3000 Hz are available for MB modulation.

MB PWR Switch OFF

When MB PWR switch S6 is in the OFF position, operating voltage is applied to the 1020 Hz generating circuits in the MB vco. The MB vco 1020 Hz output is then available for use in the VOR or LOC mode. Operating voltage is applied to the selected segment (VOR or LOC) of the VOR/LOC/MB select switch in the circuit card assembly by setting the front panel VOR or LOC 1020 Hz switch to the ON (closed) position.

The closed VOR 1020 Hz switch allows the VOR/LOR/MB select switch to complete the 1020 Hz path to the VOR modulating circuits. Likewise, the closed LOC 1020 Hz switch allows the VOR/LOC/MB select switch to complete the 1020 Hz path to LOC modulating circuits.

MB PWR Switch ON

Placing MB PWR switch S6 in the ON position inhibits the ability of the MB vco to generate 1020 Hz and enables the blue, yellow, and white MB front panel switches. By pressing one of the MB front panel switches, operating voltage is applied to MB vco in the following manner:

1. When blue MB switch S3 is depressed, operating voltage is applied to the 400 Hz generating segment of the MB vco.
2. When yellow MB switch S4 is depressed, operating voltage is applied to the 1300 Hz generating segment of the MB vco.
3. When white MB switch S5 is depressed, operating voltage is applied to the 3000 Hz generating segment of the MB vco.

The VOR/LOC/MB select switch applies the selected signal through the MB MODULATION AMP to MB rf module A1.

1-17. RF MODULES AND RF DISTRIBUTION.

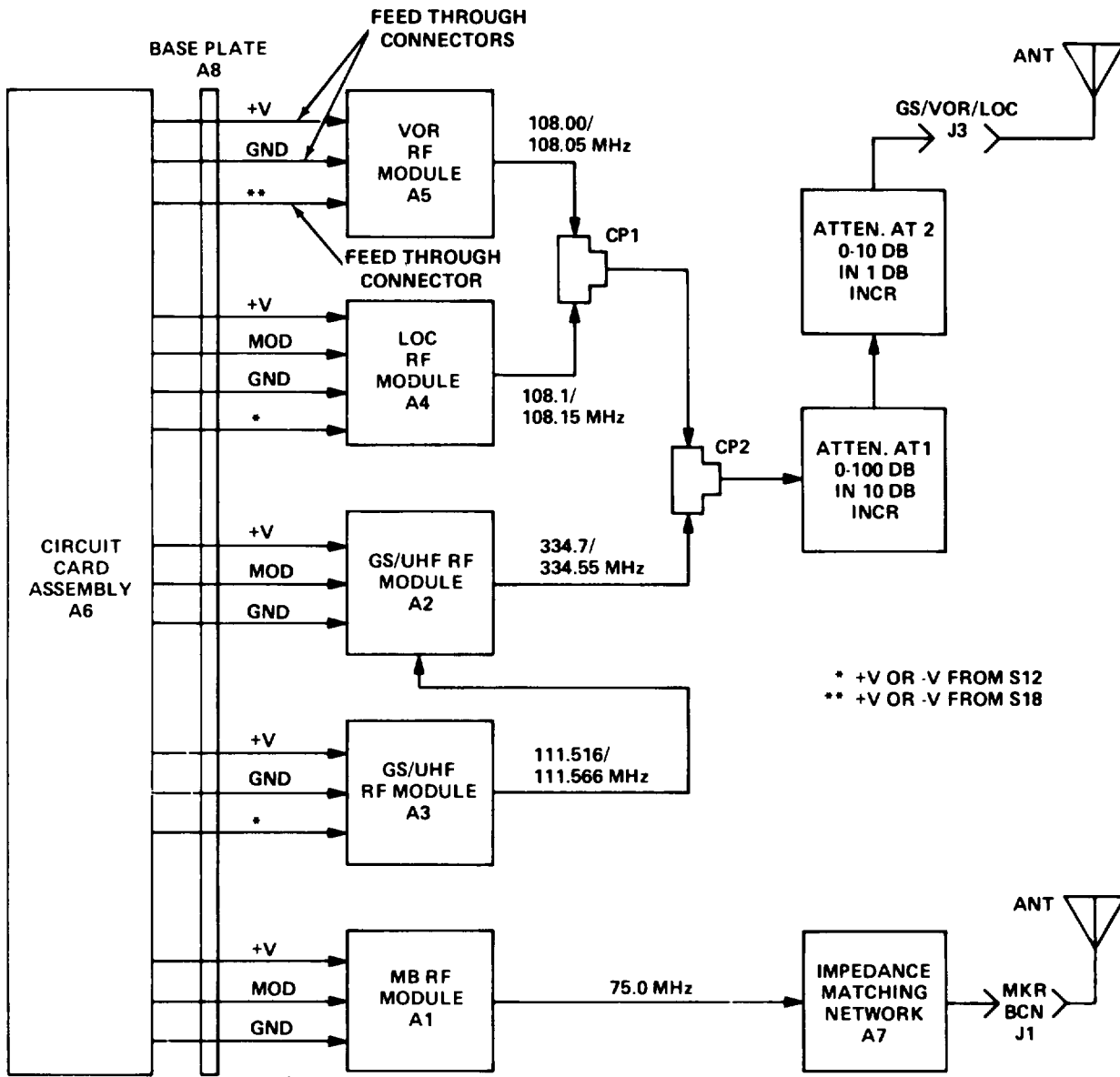

EL9MA009

1-17. RF MODULES AND RF DISTRIBUTION. (CONT)

Operating voltage and modulating signals are applied from circuit card assembly A6 to the rf modules through feed-through connectors mounted on base plate A8.

VOR, LOC, AND GS RF MODULES

The output frequencies of the VOR, LOC, and GS modules are determined by front panel frequency control switches S12 and S18 in the following manner:

1. LOC/GS frequency control switch S12 selects matched frequencies 334.70 MHz(GS) and 108.10 MHz (LOC) or 334.55 MHz (GS) and 108.15 MHz (LOC) as output frequencies for LOG rf module A4 or GS/UH F rf module A2.
2. VOR frequency control switch S18 selects 108.00 MHz or 108.05 MHz as the output for VOR rf module A5.

S12 and S18 apply positive or negative voltage to LOC rf module A4, GS/VHF rf module A3, and VOR rf module A5. The polarity of the applied voltage determines the output carrier frequencies of the modules. When positive voltage is applied, the GS/LOC modules output will be 334.55/108.15 MHz and the VOR module output will be 108.05 MHz. When negative voltage is applied, the GS/LOC modules output will be 334.70/108.10 MHz and the VOR module output will be 108.00 MHz. These carriers are modulated within their modules by the modulating frequencies produced by the circuit card assembly (para 1-16).

GS/UHF rf module A2 receives the unmodulated output of GS/VHF module A3 through a coaxial cable. GS modulation is applied to the GS/UHF module only.

The rf outputs of the VOR, LOC, and GS/UHF rf modules are applied through coaxial cables and T-connectors CP1 and CP2 to attenuators AT1 and AT2. The attenuator applies from 0 to 110 db before passing the rf signal to VOR/LOC/GS antenna jack J3, from which it is radiated through the antenna.

MB RF MODULE

When a MB front panel selector switch (S3, S4, or S5) is pushed, it routes a modulating signal (para 1-16) to MB rf module A1, and the module generates an appropriately modulated 75 MHz carrier. The rf output is applied through the impedance matching network in module A7 and MB antenna jack J1 to the separate MB antenna for radiation.

1-18. VAR LAMP FLASHER CAPABILITY.

Refer to FO-7 while reading the text in this section.

The GS, LOC, or VOR variable mode is selected by depressing lamp/switch S23, S24, or S25 respectively. When depressed, the switch contacts transfer positive voltage, thereby changing the voltage path and initiating the lamp flashing function. The three modes (GS, LOC, and VOR) use the same lamp flashing circuit, but control different signal paths. The signal paths have already been discussed in paragraph 1-16. Therefore, this paragraph will cover only the common lamp flashing circuit.

1-18. VAR LAMP FLASHER CAPABILITY. (CONT)

Positive potentials applied through the 30 REF and 30 VAR switches hold C2 and C4 paths of U18 closed. Pressing lamp switch S25 transfers the positive potential from U18 C3 to C1, thereby changing the signal path to place VOR variable R3 in the circuit.

At the same time, S25 applies +8 v through the lamp to the lamp flasher circuit at CR6. The initial application of positive voltage through the lamp causes the conduction of Q6 to decrease, allowing C37 to charge and causing the negative input to U33A to change to a negative direction. The output of U33A changes to a positive direction, causing Q7 to conduct. Q7, in turn, lights the lamp and causes the input of Q6 to become more negative. Q6 conducts harder, discharging C37 and causing the U33A input to become more positive. As a result, Q7 turns off, Q6 conduction decreases, and C37 again begins to charge. The cycle repeats itself, periodically blinking the lamp, as long as S25 remains depressed.

1-19. BATTERY CHARGER FUNCTION.

Refer to FO-8 while reading the text in this section.

The battery charger is wired for 115 vac operation, However, 230 vac operation is possible by rewiring the transformer. Instructions for rewiring the transformer are provided in paragraph 2-34.

The battery charger accepts input voltage from plug P1 through 0.5 amp fuse F1.

NOTE

if test set is wired for 230 vac operation, F1 is a 0.25 amp fuse.

Lamp DS1 lights to indicate that the battery charger has power applied,

The battery charger converts ac power to + 8 vdc and -8 vdc by utilizing a transformer T1, half-wave rectifiers CR1 and CR2, RC filters, and voltage regulating zener diodes.

Ac power from P1 is applied through fuse F1 and transformer T1 to half-wave rectifiers CR1 and CR2. CR1 cuts off the negative half of the input sine wave and passes the positive half to RC filter C1 and R1. C1 charges during conduction of the positive part of the wave and discharges through R1 during the clipping of the negative part of the wave.

1-19. BATTERY CHARGER FUNCTION. (CONT)

This action produces an output of + 8 vdc regulated by zener diode CR3. +8 vdc from point E1 is applied to A of P2.

CR2 clips off the positive half of the input sine wave and passes the negative half to RC filter C2 and R2. C2 charges during conduction of the negative part of the wave and discharges through R2 during the clipping of the positive part of the wave.

This action produces an output of -8 vdc regulated by zener diode CR4. -8 vdc from point E2 is applied to B of P2.

Resistors R3 and R4 are preset to cause their respective zener diodes to conduct and establish each output at 9.2 vdc.

The battery charger is used to trickle-charge the two test set batteries simultaneously.

The battery charger output is applied to the test set at plug P2. P2 connects to test set jack J2.

CAUTION

Do not remove power from battery charger while connected to test set. Test set will discharge through battery circuitry.

CHAPTER 2 MAINTENANCE

| Subject | Section | Page |
|--|---------|------|
| Repair Parts, Special Tools, TMDE, and Support Equipment | I | 2-1 |
| Performance Test Procedures | II | 2-1 |
| Troubleshooting | III | 2-34 |
| Alinement Procedures | IV | 2-39 |
| Maintenance Procedures | V | 2-59 |

Section I REPAIR PARTS, SPECIAL TOOLS, TMDE, AND SUPPORT EQUIPMENT

| Subject | Para | Page |
|--|------|------|
| Special Tools, TMDE, and Support Equipment | 2-1 | 2-1 |
| Repair Parts | 2-2 | 2-1 |

2-1. SPECIAL TOOLS, TMDE, AND SUPPORT EQUIPMENT.

For special tools, TMDE, and support equipment required for general support maintenance of the test set, refer to the Maintenance Allocation Chart (MAC) in TM 11-6625-2976-12, and the repair parts and special tools list (RPSTL), TM 11-6625-2976-24P.

2-2. REPAIR PARTS.

Repair parts are listed and illustrated in the repair parts and special tools list (RPSTL), TM 11-6625-2976-24P.

Section II PERFORMANCE TEST PROCEDURES

| Subject | Para | Page |
|--|------------|------|
| General | 2-3 | 2-1 |
| How to Use the Performance Test Charts | 2-4 | 2-2 |
| Performance Test Procedures | 2-5 | 2-4 |

2-3. GENERAL.

The performance tests in this section are diagnostic in purpose. They will enable you to determine whether or not a test set is operating acceptably. Each test procedure checks a specific function of the test set to help you find and isolate faults.

Each test is complete and maybe performed individually. Therefore, you may choose the appropriate test to verify gross equipment failure or performance degradation of a specific mode. However, this maintenance approach is not recommended. it is best to perform all the tests, in sequence.

This systematic maintenance approach will ensure that all faults are found and corrected.

The performance test procedures appear in the form of logic flow charts. information covering the use of these charts is contained in the following paragraph.

2-4. HOW TO USE THE PERFORMANCE TEST CHARTS.

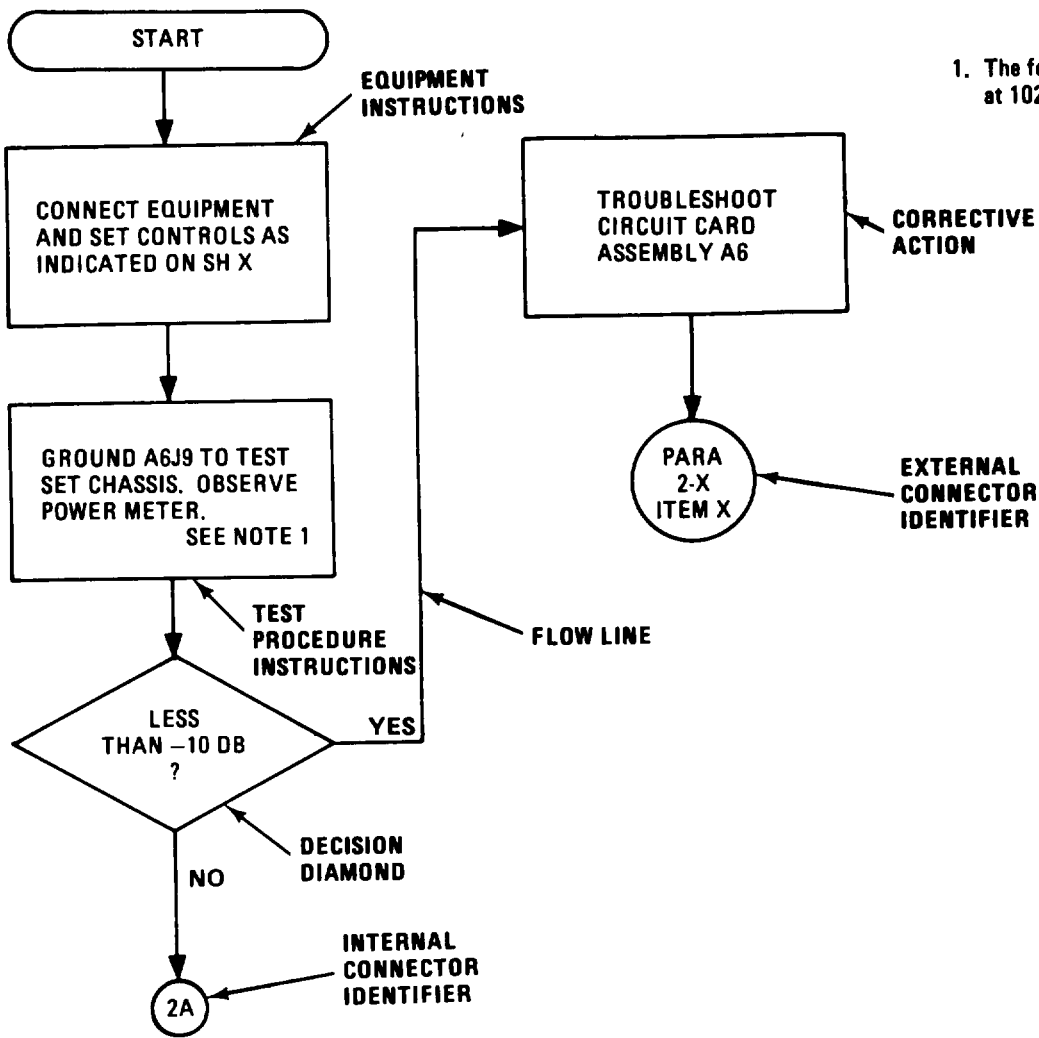

NOTE

1. The following measurement checks distortion at 1020 Hz.

The preceding illustration is an example of a logic flow chart. Refer to the illustration while reading the following information.

START

Each individual chart contains a start segment indicating the start of the test procedure.

2-4. HOW TO USE THE PERFORMANCE TEST CHARTS. (CONT)

EQUIPMENT INSTRUCTIONS

Equipment Instructions are contained in a rectangular box. They provide details concerning proper hookup of test equipment and correct control settings necessary to perform the test procedure.

The initial equipment instructions found at the beginning of each chart reference a sheet number where an equipment test setup diagram can be found. The sheet number is located at the top of each page of the chart, below the chart number and title.

Within a test procedure, changes of equipment control settings, and even hookups, are often required. These changes are detailed in the equipment instruction boxes. At any step in the chart, the equipment status is always that defined by the nearest previous equipment instruction box in the chain.

TEST PROCEDURE INSTRUCTIONS

This rectangular box provides general test procedure instructions,

DECISION DIAMOND

As a result of a particular test point probe, some electrical value should be observed, such as a power indication on a power meter. The decision diamond defines what value should be observed, and permits a yes or no decision in response to what is observed.

FLOW LINE

Flow lines provide direction to successive steps in the logic chart. An arrow at the end of each flow line indicates the next step in the procedural chain.

INTERNAL CONNECTOR IDENTIFIER

There are two sizes of circular identifiers used in the charts. The smaller of the two is the internal connector identifier. The internal connector identifier indicates a continuation of the procedure to another sheet in the same flow chart. The sheet on which the procedure is continued contains a corresponding identifier, ie, a small circle in which the same number and letter are printed. The number in the circle indicates on which sheet the test procedure continues. For example, in the sample flowchart the NO branch of the decision diamond flows to the identifier containing 2A. This means that the procedure is continued on sheet 2, at the small circle containing 2A.

CORRECTIVE ACTION OR ADDITIONAL INSTRUCTION

A corrective action or additional instruction box always follows a decision diamond. If a test set response does not meet the standard set in the decision diamond, the appropriately marked flow line from the decision diamond will be followed to a corrective action box, which contains a specific troubleshooting reference. If the test set response meets the standard, the flow line will be followed to an additional instruction box, which will either continue with the same performance test, or state that the equipment has met all this performance test's standards and refer to the next performance test.

2-4. HOW TO USE THE PERFORMANCE TEST CHARTS. (CONT)

EXTERNAL CONNECTOR IDENTIFIER

The external connector identifier is a large circle which contains the paragraph number of the troubleshooting chart and a specific item on that chart, or the number of the next chart in the performance test sequence. Therefore, a large circle always references some information external to the flow chart containing the circle.

NOTE

An external connector identifier always completes the performance test chain.

NOTES

The third column on each performance test chart sheet may contain notes to clarify information contained in the chart.

2-5. PERFORMANCE TEST PROCEDURES.

TEST EQUIPMENT REQUIRED

Dual-Volt Power Supply, HP PS503A
Digital Voltmeter, HP 3490A

PRELIMINARY EQUIPMENT SETUP

WARNING

Dangerous potentials exist at several points throughout this equipment. When equipment is operated with case removed, do not touch exposed connections or components.

CAUTION

Remove all jewelry while performing maintenance procedures. Shorting metal or jewelry to exposed connections may damage test set.

Before beginning the performance tests, complete the following preliminary procedures.

1. Remove electronic component assembly from case (para 2-17).
2. Place electronic component assembly face upon level surface.
3. Remove batteries from Battery case. (Refer to TM 11-6625-2976-12.)
4. Open air pressure valve.
5. Using screwdriver, loosen 10 screws securing test set to case and remove test set from case.

2-5. PERFORMANCE TEST PROCEDURES. (CONT)

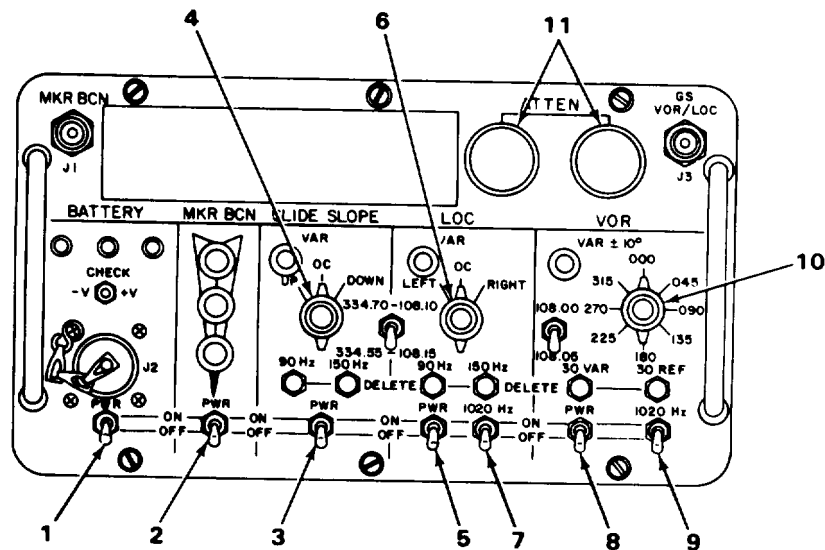

6. Set test set controls as indicated in the following table,

| KEY | CONTROL/SWITCH | POSITION/SETTING |
|-----|------------------------|------------------|
| 1 | BATTERY PWR | OFF |
| 2 | MKR BCN PWR | OFF |
| 3 | GLIDE SLOPE PWR | OFF |
| 4 | GLIDE SLOPE UP/OC/DOWN | OC |
| 5 | LOC PWR | OFF |
| 6 | LOC LEFT/OC/RIGHT | OC |
| 7 | LOC 1020 HZ | OFF |
| 8 | VOR PWR | OFF |
| 9 | VOR 1020 HZ | OFF |
| 10 | VOR bearing | 000 |
| 11 | ATTEN controls (both) | 0 |

7. Plug power supply and voltmeter into 115 **vac** outlet.

8. Turn power supply power switch to off position and set voltmeter to correct scale (8 vdc measured).

2-5. PERFORMANCE TEST PROCEDURES. (CONT)

CAUTION

Use extreme care when connecting power to test set. Damage to equipment will result if polarity is incorrect.

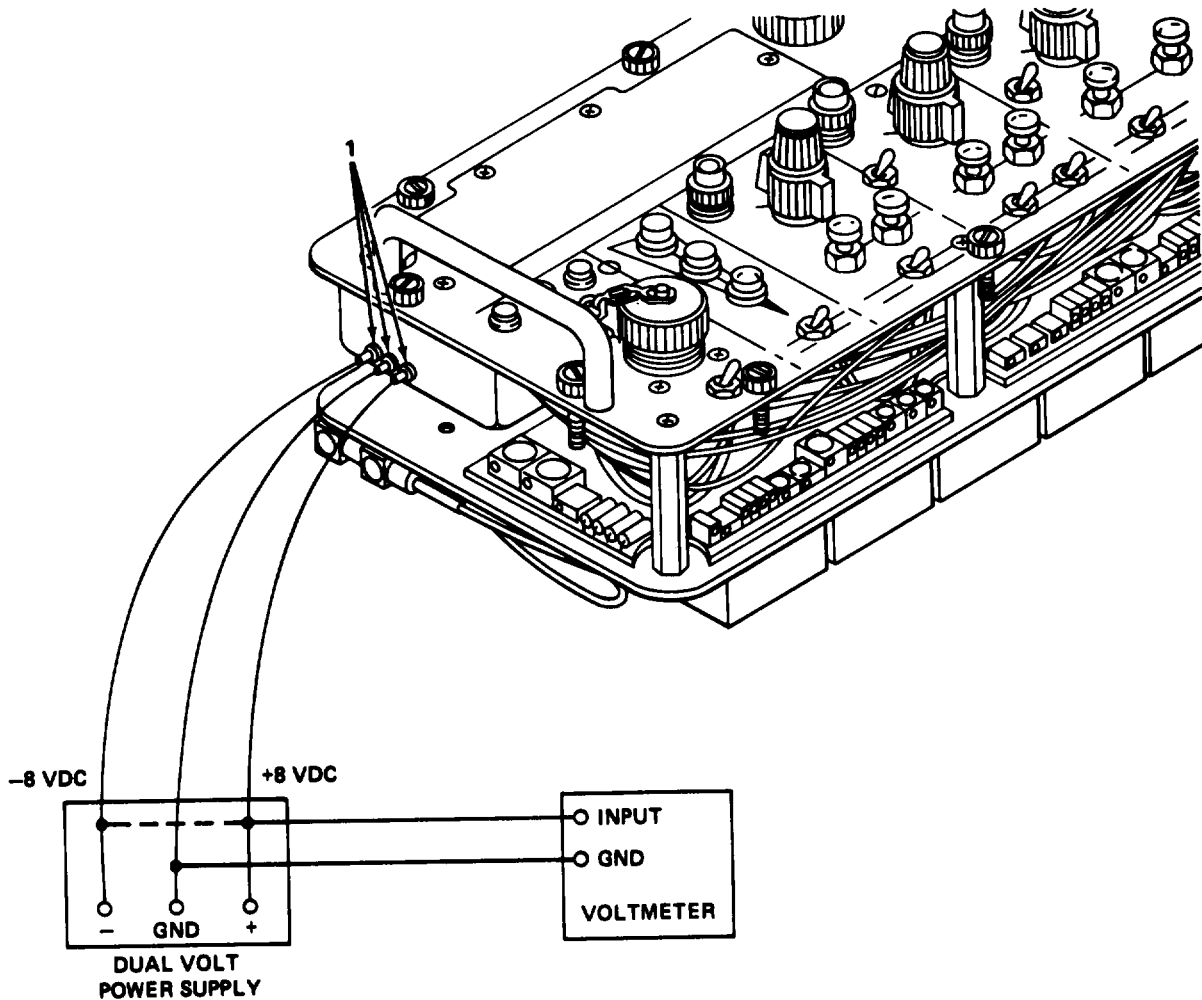

EL9MA077

9. Using three single banana plug-to-test hook leads, connect dual volt power supply test leads to battery box tie points (1). Connect negative (-) terminal to tie point with orange wire. Connect ground terminal to tie point with black wire. Connect positive(+) to tie point with red wire.
10. Turn on dual volt power supply and adjust supply controls for +8vdc and -8 vdc output. Verify using voltmeter.

2-5. PERFORMANCE TEST PROCEDURES. (CONT)

CHART 2-1
Frequency Accuracy Performance Test
(Sheet 1 of 3)

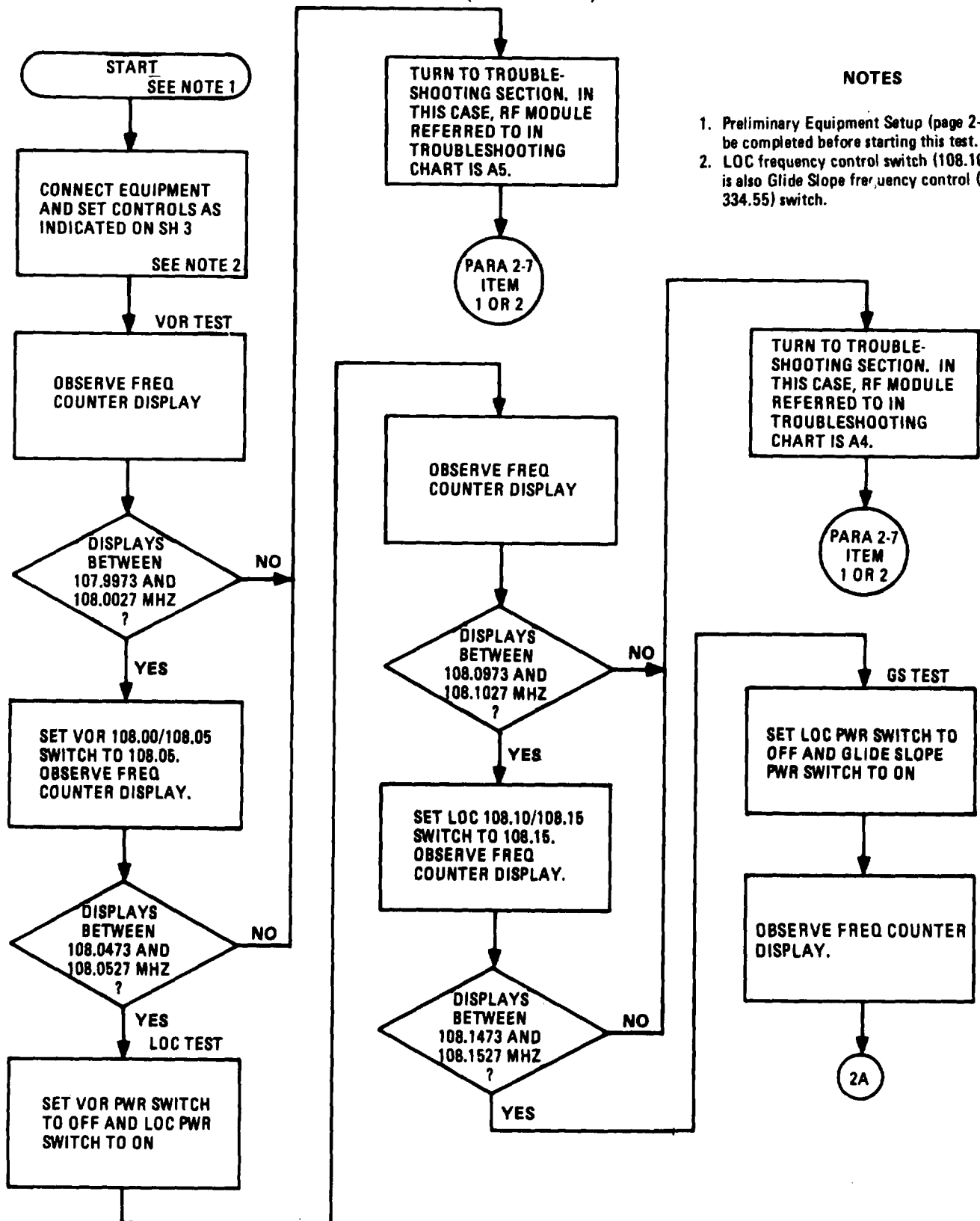

NOTES

1. Preliminary Equipment Setup (page 2-4) must be completed before starting this test.
2. LOC frequency control switch (108.10/108.15) is also Glide Slope frequency control (334.70/334.55) switch.

2-5. PERFORMANCE TEST PROCEDURES. (CONT)

CHART 2-1
Frequency Accuracy Performance Test
(Sheet 2 of 3)

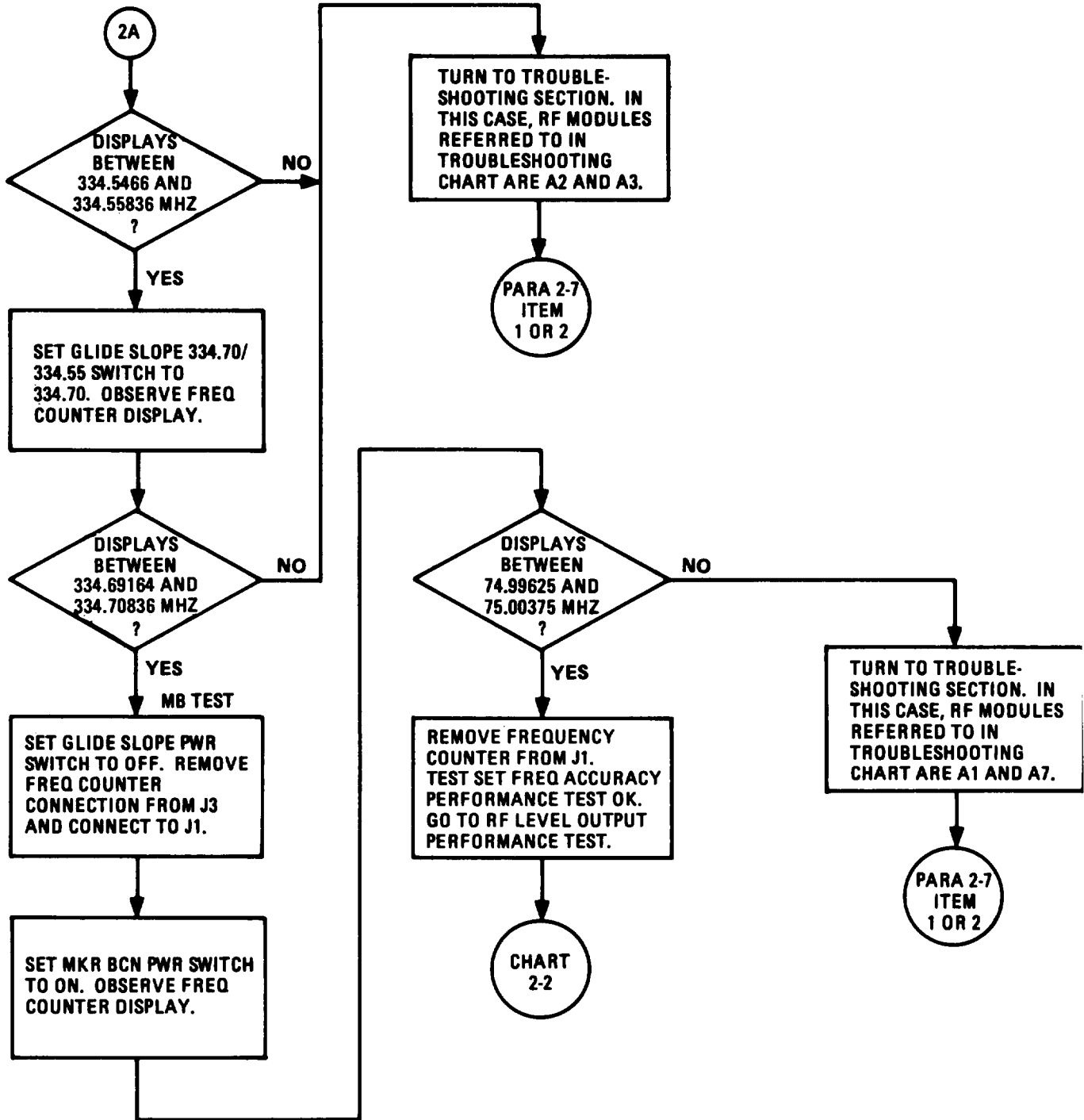

2-5. PERFORMANCE TEST PROCEDURES. (CONT)

CHART 2-1
Frequency Accuracy Performance Test
(Sheet 3 of 3)

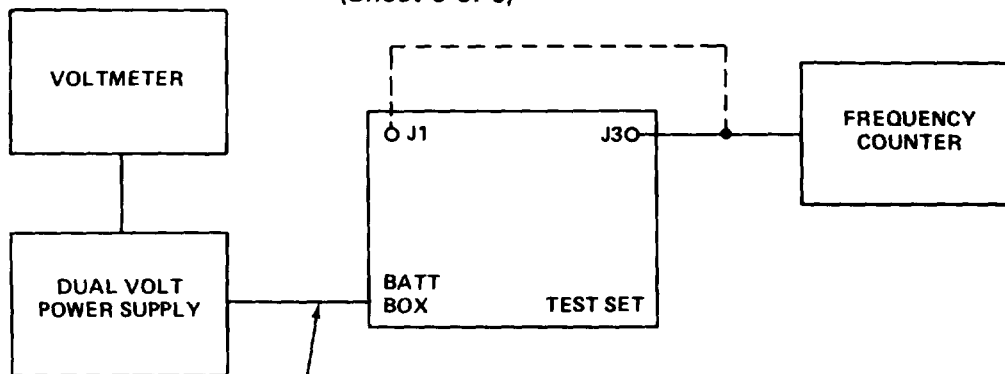

SEE
PRELIMINARY
PROCEDURE

CONTROL AND SWITCH SETTINGS

EL9MA036

Test set control settings are same as in Preliminary Equipment Setup, page 2-4, except as indicated below.

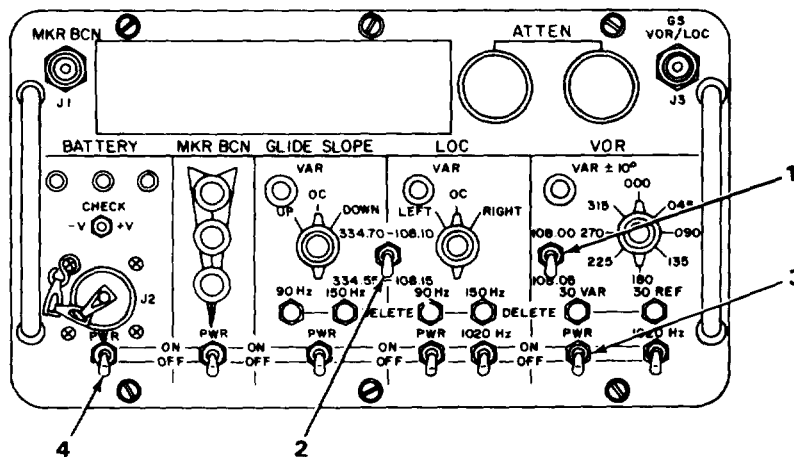

EL9MA037

| KEY | CONTROL/SWITCH | POSITION/SETTING |
|-----|--|------------------|
| 1 | VOR Frequency Control (108.00/108.05) switch | 108.00 |
| 2 | LOC Frequency Control (108.10/108.15) switch | 108.10 |
| 3 | VOR PWR switch | ON |
| 4 | BATTERY PWR switch | ON |

2-5. PERFORMANCE TEST PROCEDURES. (CONT)

CHART 2-2
RF Level Output Performance Test
(Sheet 1 of 3)

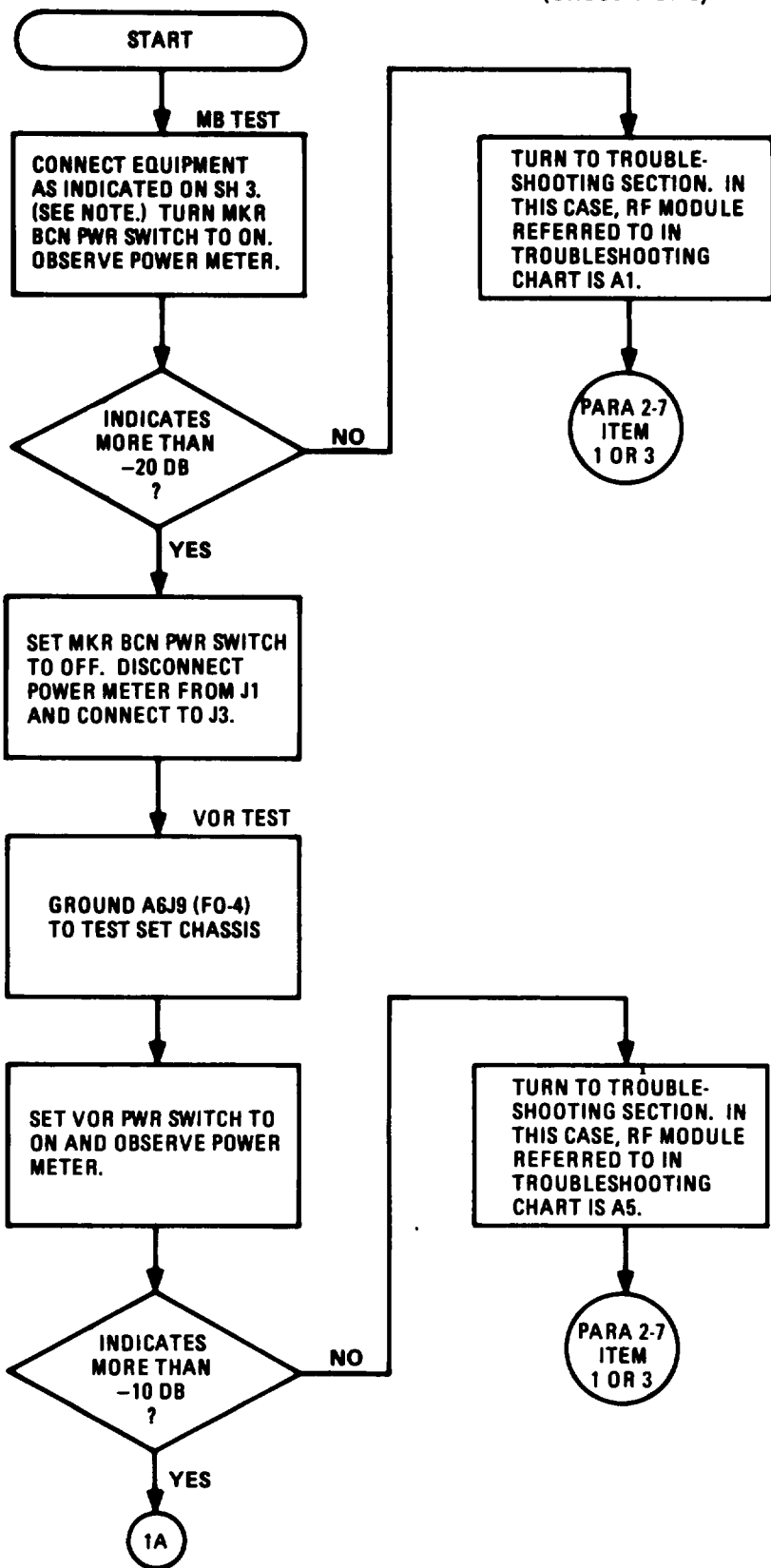

NOTE

If you are doing the performance tests in sequence, the test set controls are already set correctly. That is, they are the same as those at the end of the Frequency Accuracy Performance Test, except for the following MKR BCN PWR switch adjustments.

If you wish to do this test alone, or are starting with this test, you must first complete the Preliminary Equipment Setup, page 2-4.

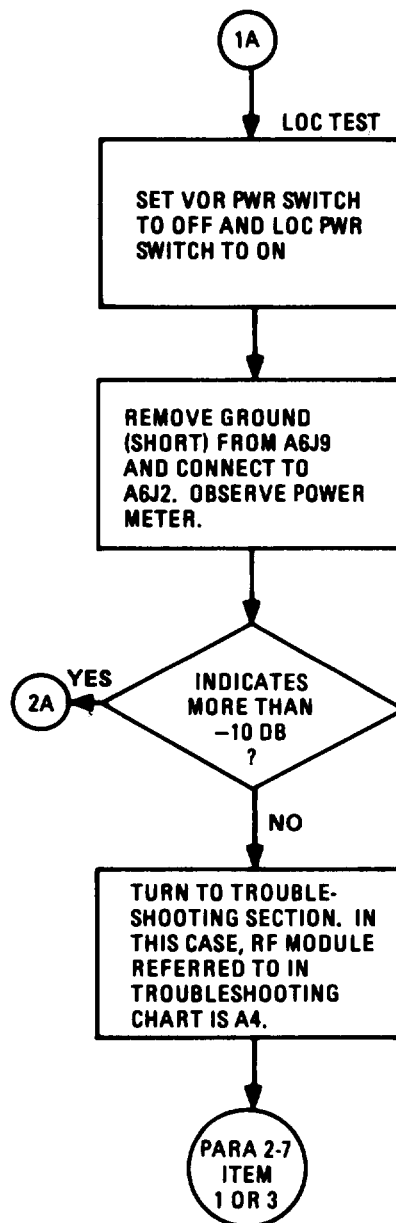

2-5. PERFORMANCE TEST PROCEDURES. (CONT)

CHART 2-2
 RF Level Output Performance Test
 (Sheet 2 of 3)

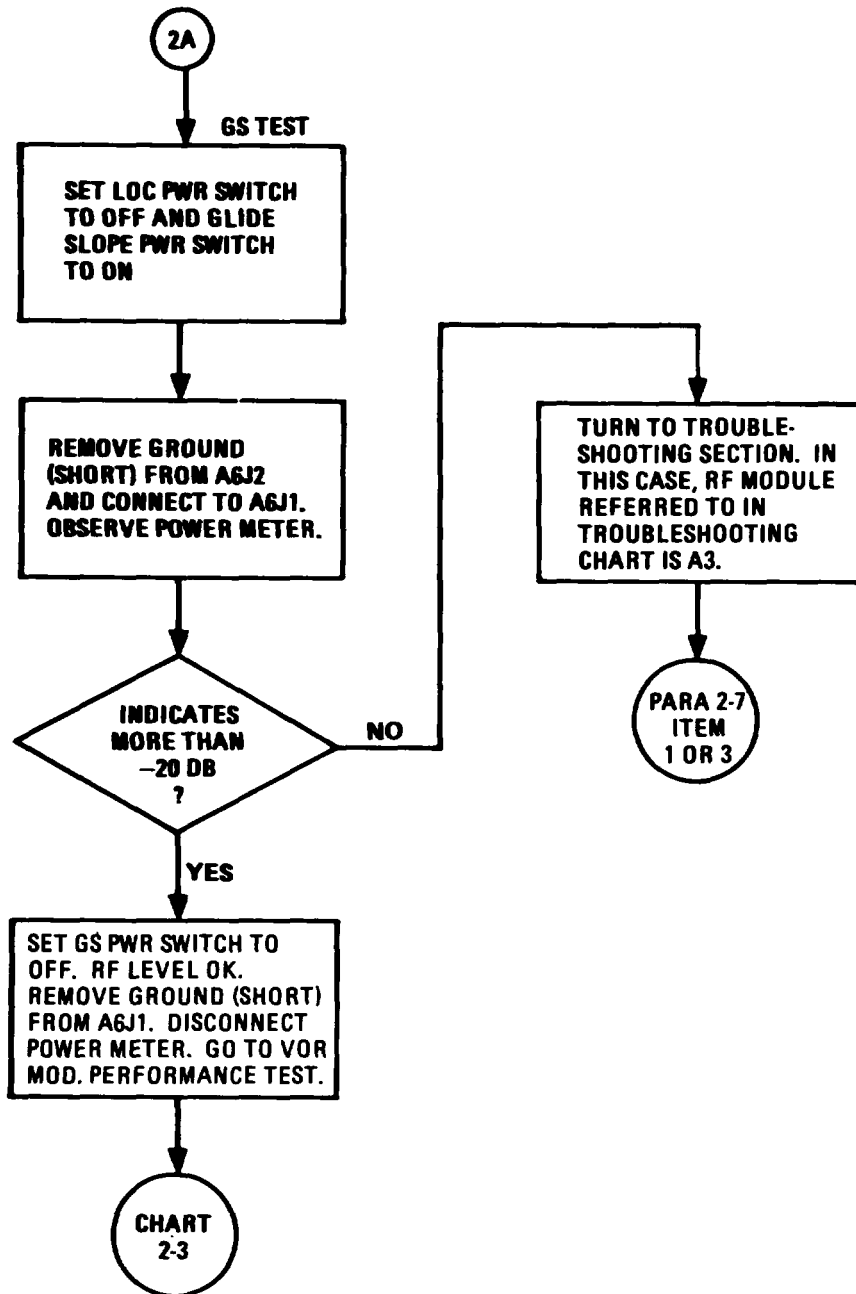

2-5. PERFORMANCE TEST PROCEDURES. (CONT)

CHART 2-2
RF Level Output Performance Test
(Sheet 3 of 3)

TEST EQUIPMENT

Power Meter HP432A
Thermistor Mount HP-478-A

TEST SETUP

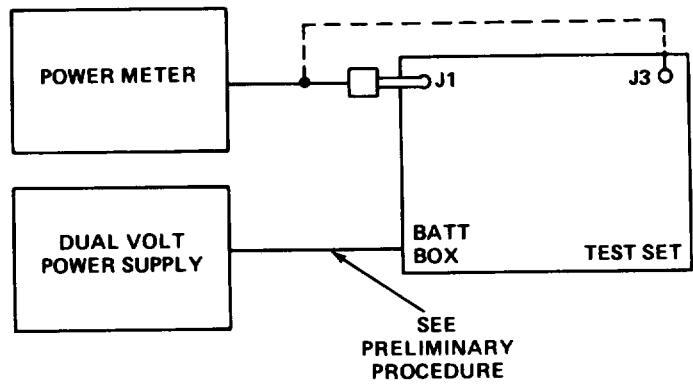

EL9MA038

2-5. PERFORMANCE TEST PROCEDURES. (CONT)

CHART 2-3
VOR Modulation Performance Test
(Sheet 1 of 3)

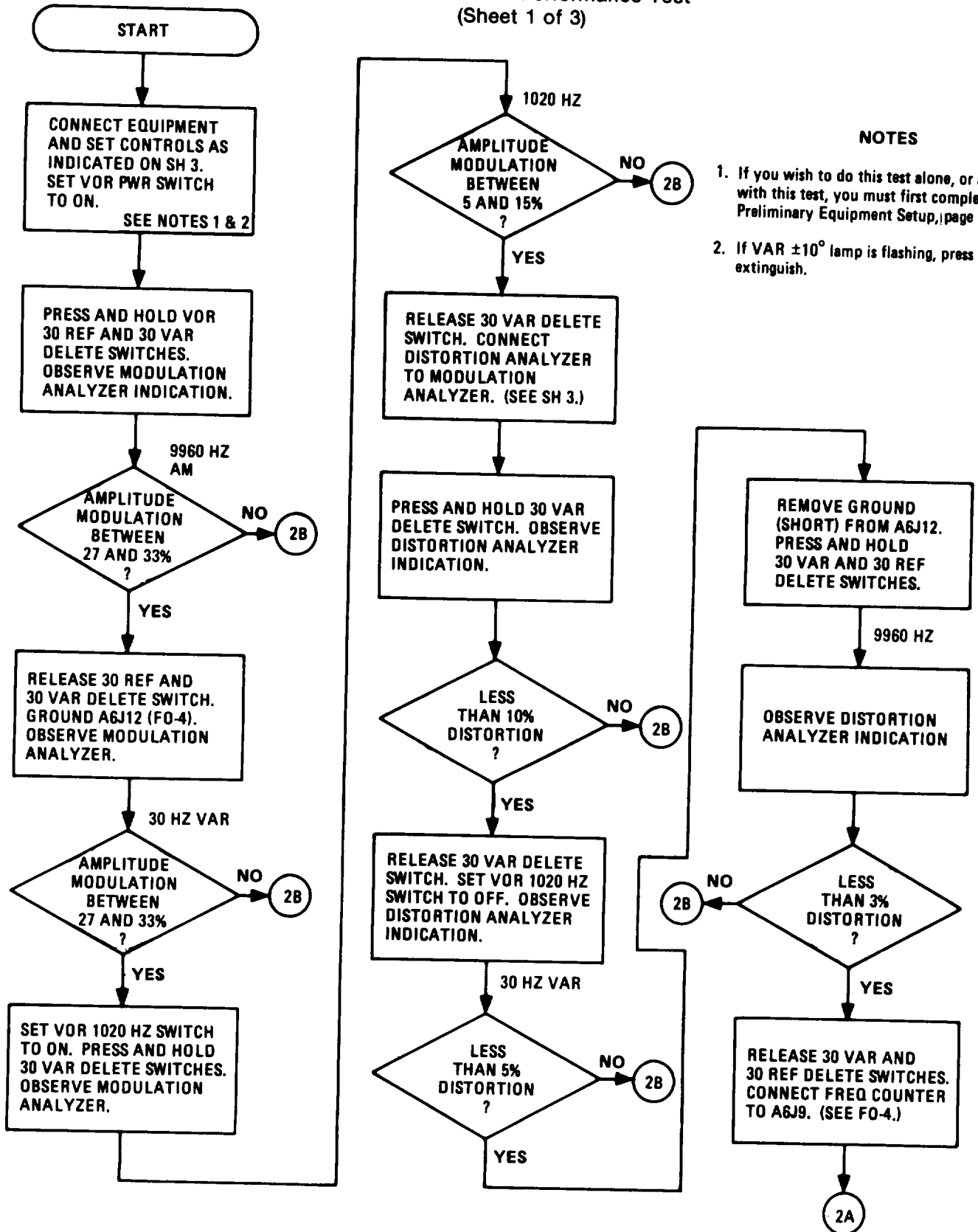

NOTES

1. If you wish to do this test alone, or are starting with this test, you must first complete the Preliminary Equipment Setup, page 2-4.
2. If VAR $\pm 10^\circ$ lamp is flashing, press to extinguish.

2-5. PERFORMANCE TEST PROCEDURES. (CONT)

CHART 2-3
VOR Modulation Performance Test
(Sheet 2 of 3)

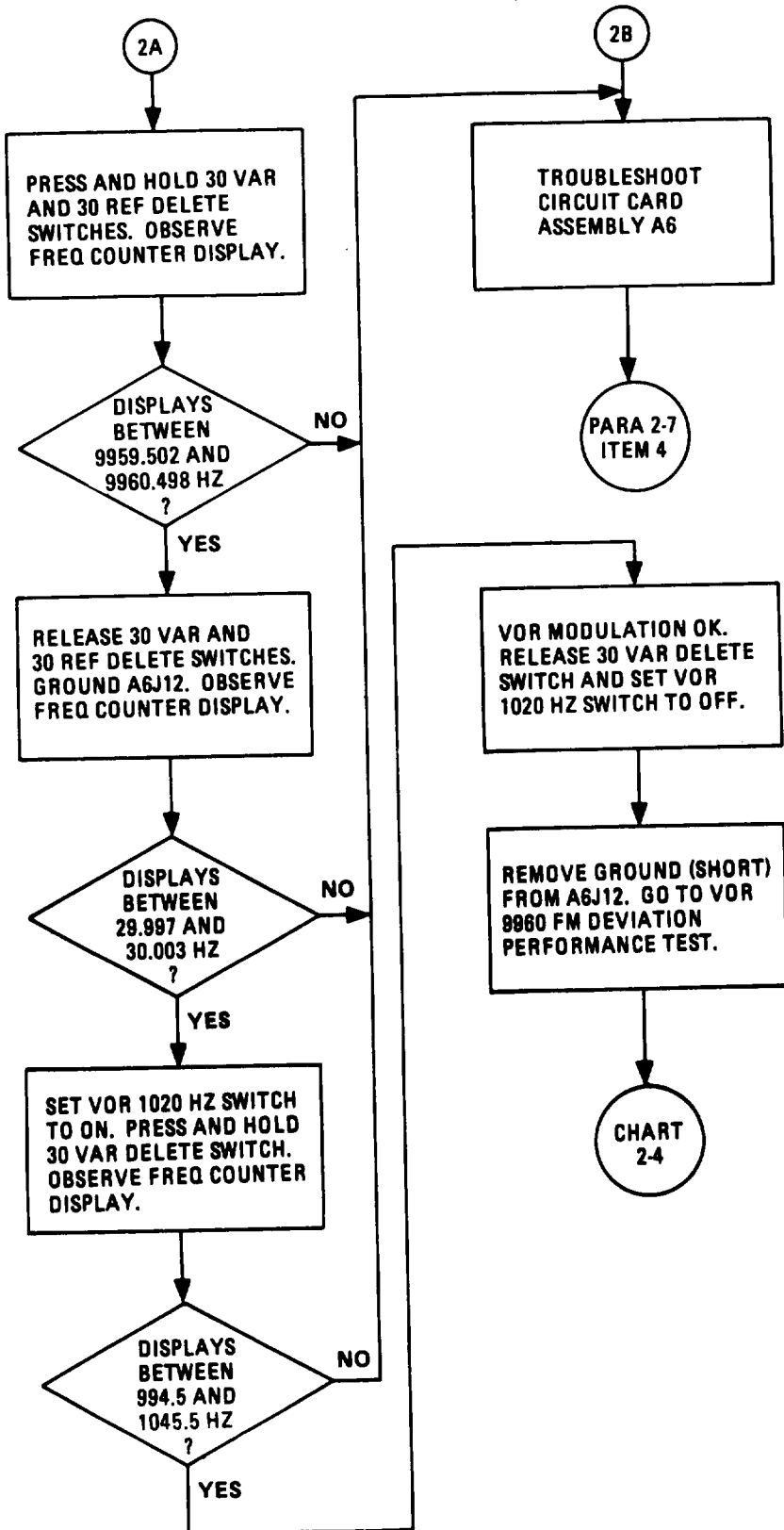

2-5. PERFORMANCE TEST PROCEDURES. (CONT)

CHART 2-3
 VOR Modulation Performance Test
 (Sheet 3 of 3)

TEST EQUIPMENT

Modulation Analyzer HP 8901A
 Frequency Counter HP 54345A
 Power Supply PS503A
 Distortion Analyzer C41-334A

TEST SETUP

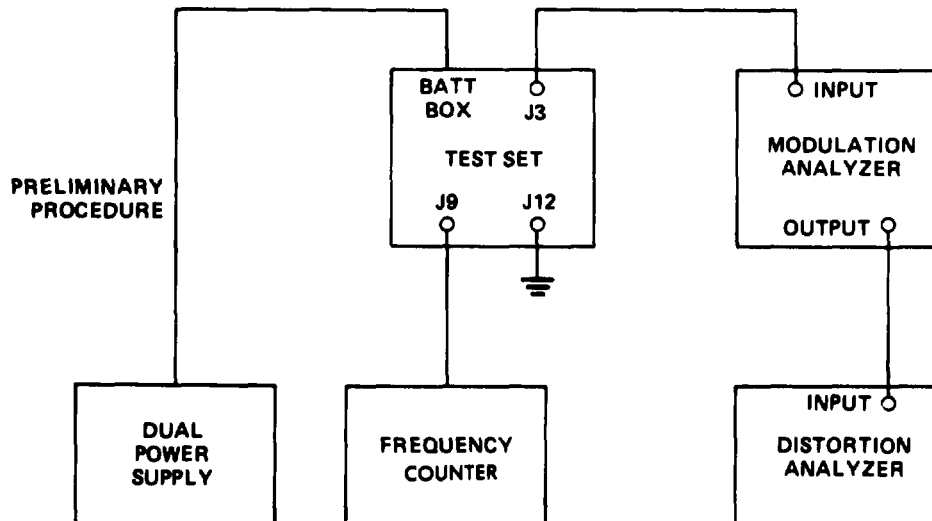

EL9MA078

2-5. PERFORMANCE TEST PROCEDURES. (CONT)

CHART 2-4
 VOR 9960 FM Deviation Performance Test
 (Sheet 1 of 2)

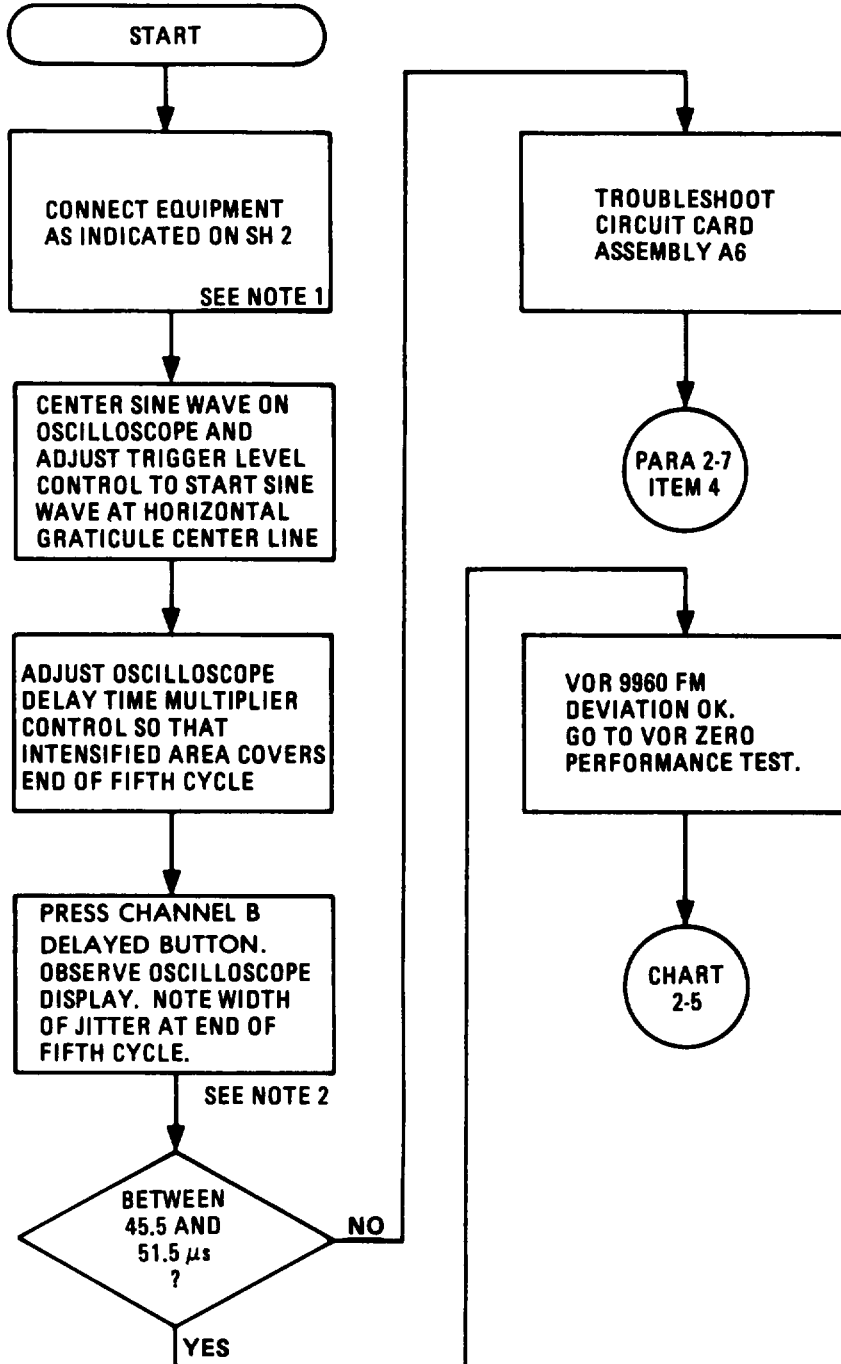

NOTES

1. If you are doing the performance tests in sequence, the test set controls are already set correctly. That is, they are the same as those at the end of the VOR Modulation Performance Test.

If you wish to do this test alone, or are starting with this test, complete the Preliminary Equipment Setup, page 2-4. Then after setting up the equipment used in this test, set the VOR PWR switch to ON.

2. The width of the jitter is proportional to the 9960 Hz FM. A 9960 Hz signal deviating ± 480 Hz varies between 9480 and 10440 Hz. The period of 10440 Hz is 95.785 μ s and the time for five cycles is 478.925 μ s. The period of 9480 Hz is 105.484 μ s and the time for five cycles is 527.425 μ s. The difference between them (527.425 μ s minus 478.925 μ s) is 48.5 μ s. For a tolerance of 480 ± 30 Hz deviation, the width of the jitter must be 48.5 ± 3 μ s.

2-5. PERFORMANCE TEST PROCEDURES. (CONT)

CHART 2-4
 VOR 9960 FM Deviation Performance Test
 (Sheet 2 of 2)

TEST EQUIPMENT

Oscilloscope TEK 5440 with plug-ins 5B42 and 5A48

TEST SETUP

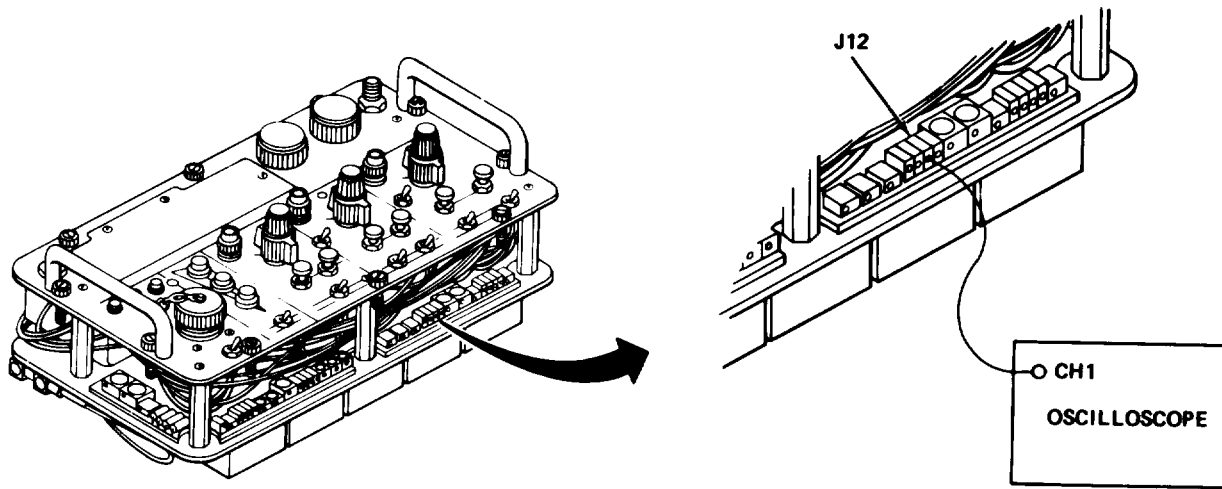

EL9MA041

CONTROL AND SWITCH SETTINGS

1. See note 1 on sheet 1 of this chart for information regarding test set settings.
2. Set oscilloscope controls as indicated below.

| CONTROL | SETTING |
|--|-------------------------------|
| VOLTS/DIVISION TIME/DIVISION A TIME/DIVISION B | 0.5 0.1 ms 10.0 μ s |

2-5. PERFORMANCE TEST PROCEDURES. (CONT)

CHART 2-5
 VOR Zero Performance Test
 (Sheet 1 of 1)

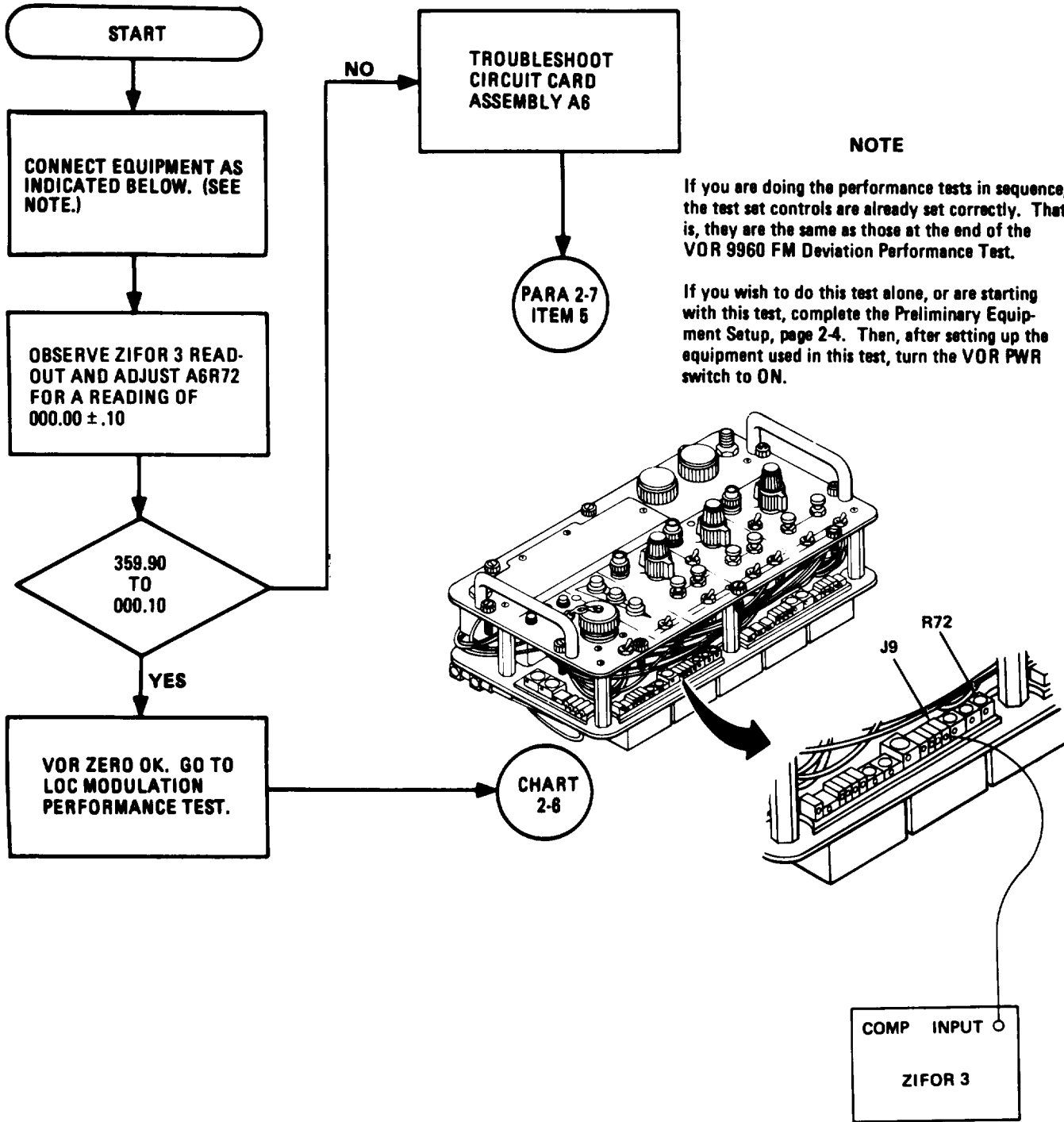

EL9MA042

2-5. PERFORMANCE TEST PROCEDURES. (CONT)

CHART 2-6
LOC Modulation Performance Test
(Sheet 1 of 3)

NOTES

1. If you are doing the performance tests in sequence, the test set control settings for this test are the same as those at the end of the VOR Zero Performance Test, except for those changes listed in the table on sh 3.

If you wish to do this test alone, or are starting with this test, you must first complete the Preliminary Equipment Setup, page 2-5.

2. If VAR lamp is flashing, press to extinguish.

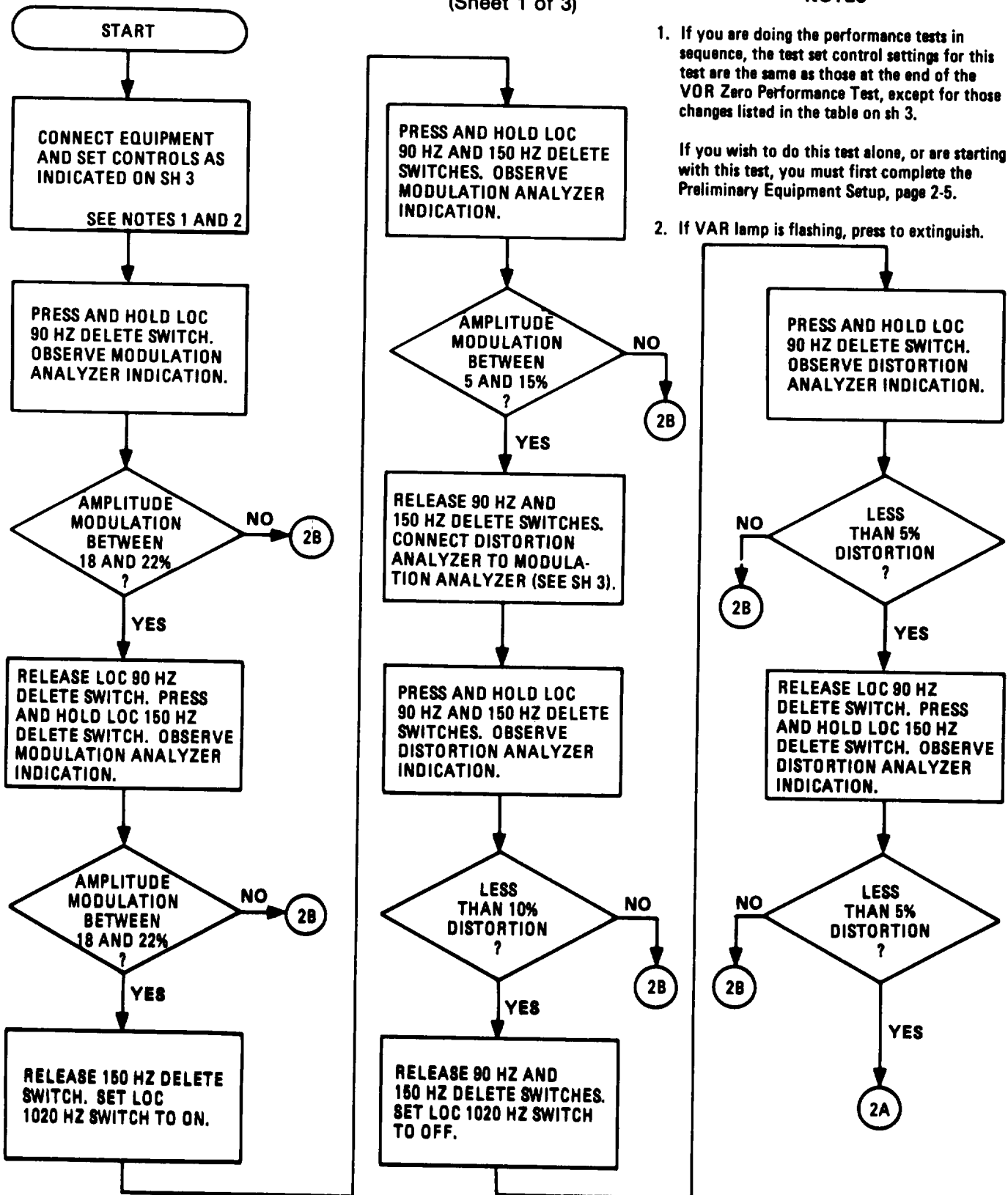

2-5. PERFORMANCE TEST PROCEDURES. (CONT)

CHART 2-6
LOC Modulation Performance Test
(Sheet 2 of 3)

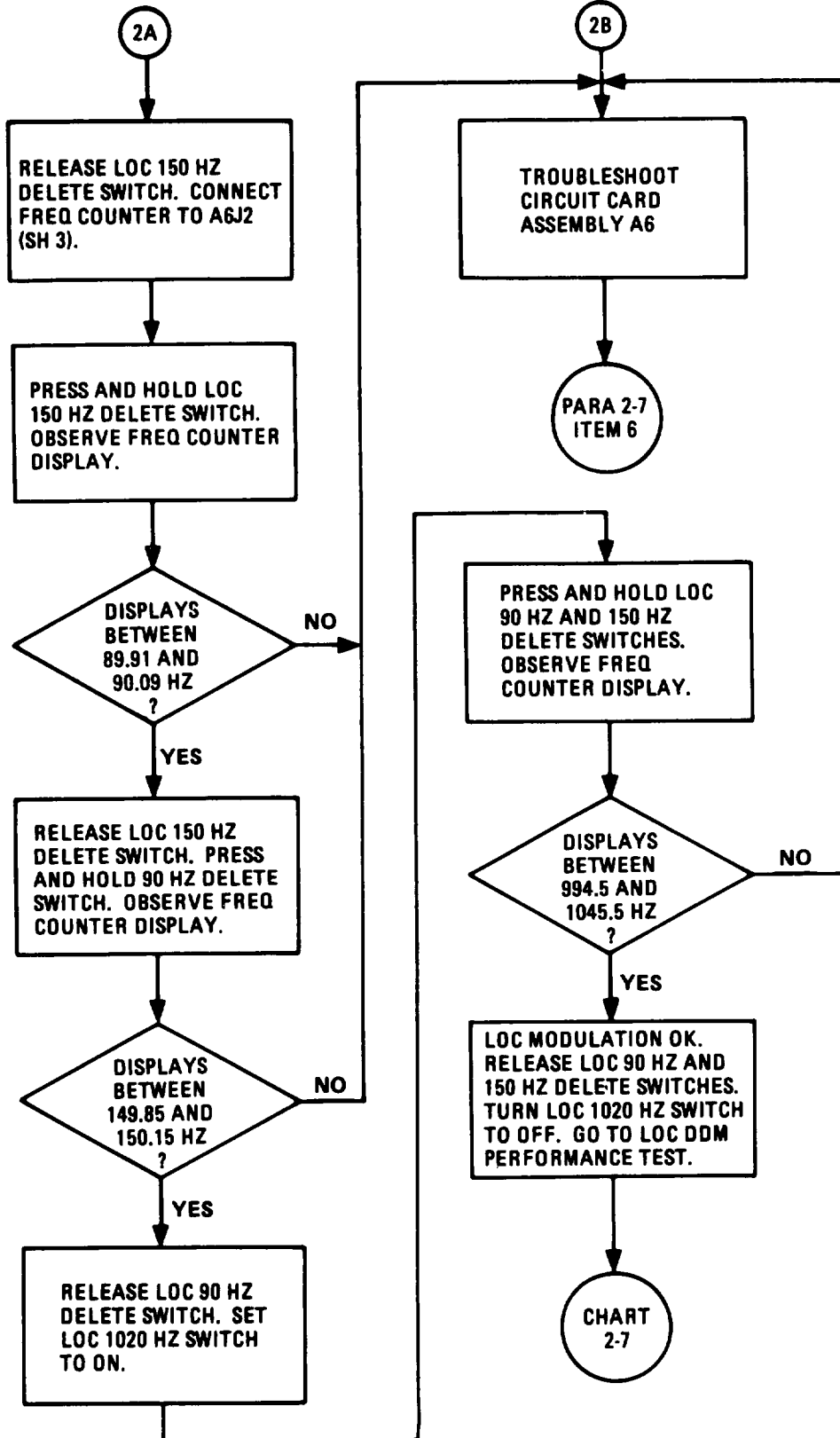

2-5. PERFORMANCE TEST PROCEDURES. (CONT)

CHART 2-6
 LOC Modulation Performance Test
 (Sheet 3 of 3)

TEST EQUIPMENT

Modulation Analyzer HP8901A
 Frequency Counter 5345A
 Power Supply PS503A
 Distortion Analyzer C41-334A

TEST SETUP

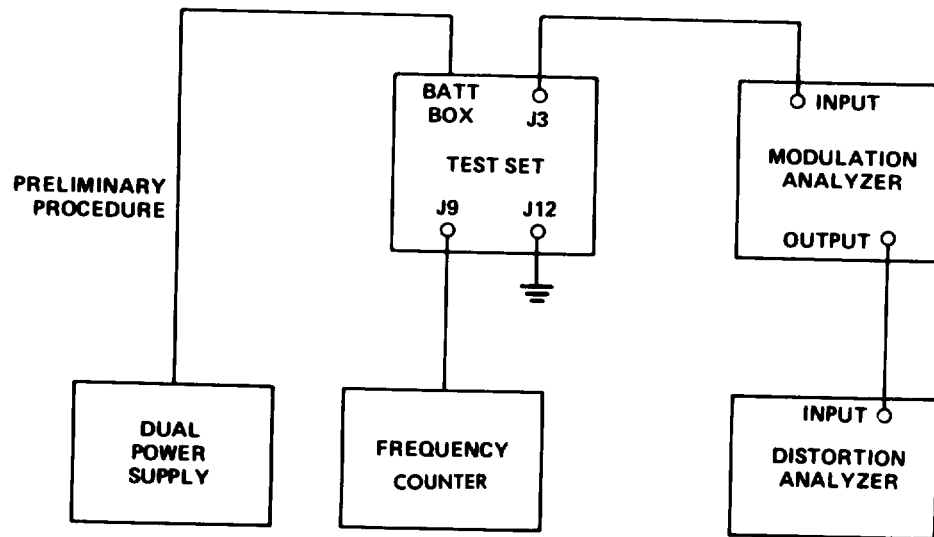

EL9MA078

2-5. PERFORMANCE TEST PROCEDURES. (CONT)

CHART 2-7
 LOC DDM Performance Test
 (Sheet 1 of 2)

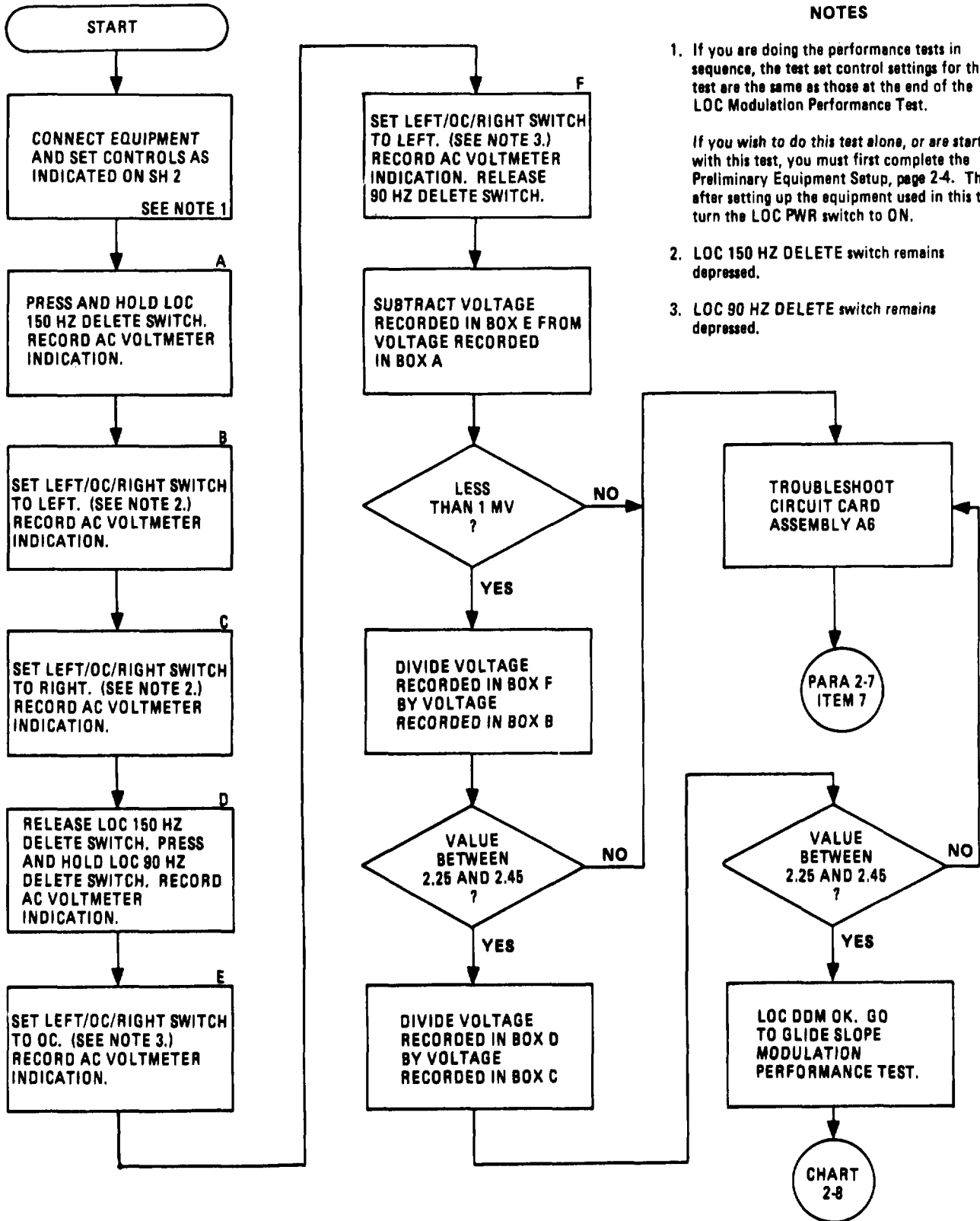

NOTES

1. If you are doing the performance tests in sequence, the test set control settings for this test are the same as those at the end of the LOC Modulation Performance Test.

If you wish to do this test alone, or are starting with this test, you must first complete the Preliminary Equipment Setup, page 2-4. Then, after setting up the equipment used in this test, turn the LOC PWR switch to ON.

2. LOC 150 HZ DELETE switch remains depressed.

3. LOC 90 HZ DELETE switch remains depressed.

2-6. PERFORMANCE TEST PROCEDURES. (CONT)

CHART 2-7
LOC DDM Performance Test
(Sheet 2 of 2)

TEST EQUIPMENT

Voltmeter HP3490A

TEST SETUP

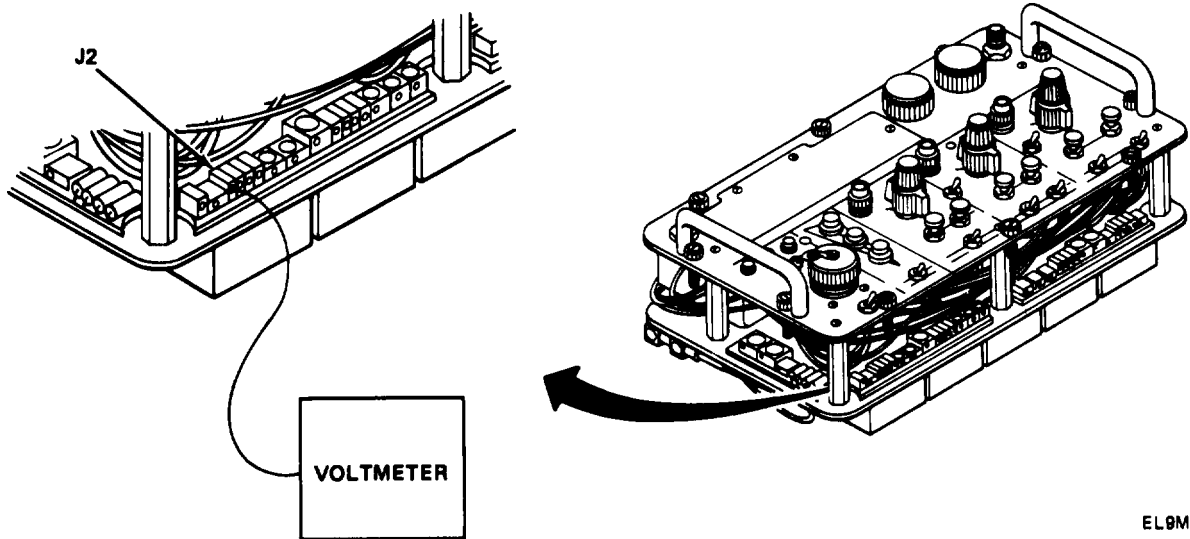

EL9MA044

2-5. PERFORMANCE TEST PROCEDURES. (CONT)

CHART 2-8
Glide Slope Modulation Performance Test
(Sheet 1 of 2)

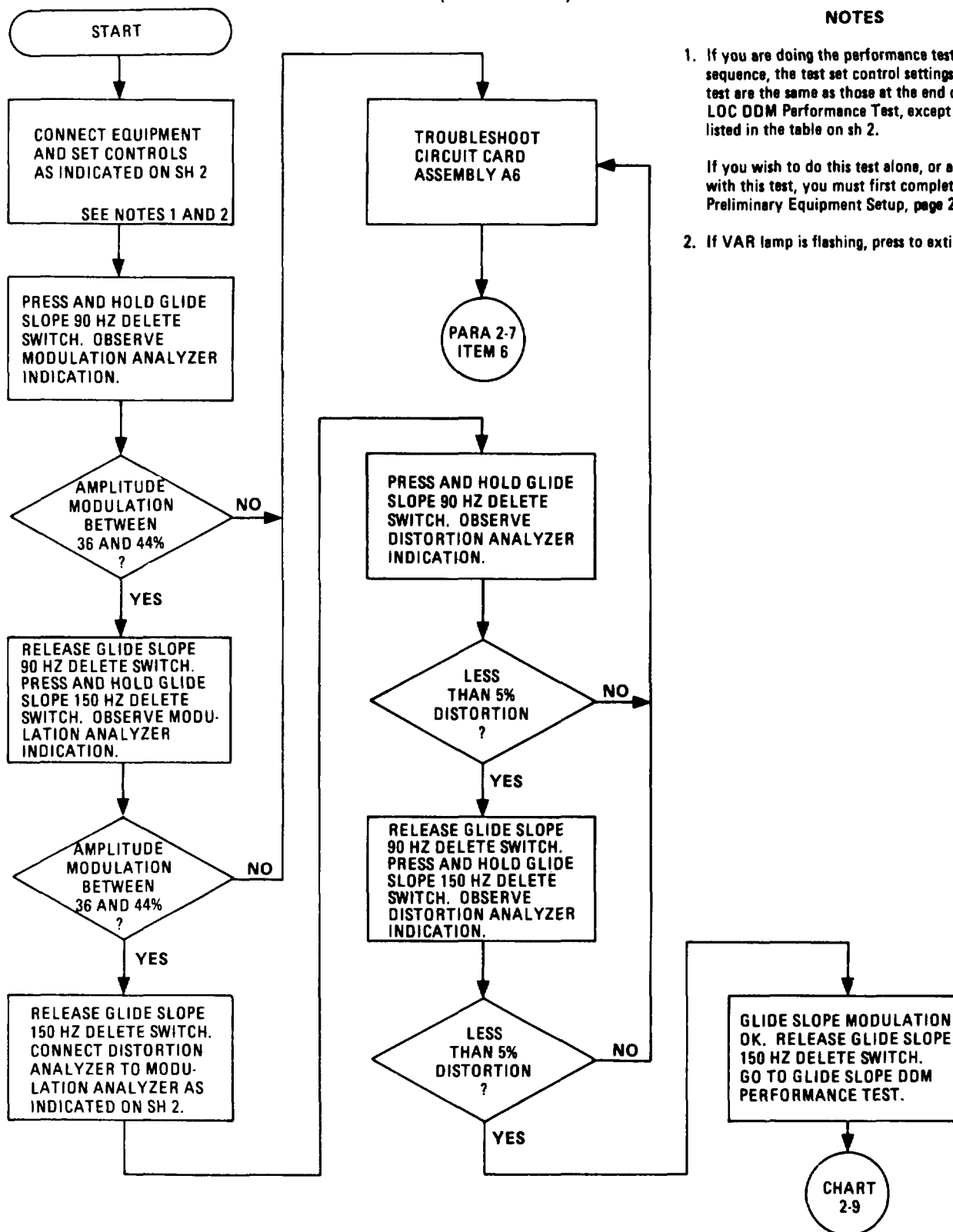

NOTES

1. If you are doing the performance tests in sequence, the test set control settings for this test are the same as those at the end of the LOC DDM Performance Test, except for those listed in the table on sh 2.

If you wish to do this test alone, or are starting with this test, you must first complete the Preliminary Equipment Setup, page 2-4.

2. If VAR lamp is flashing, press to extinguish.

2-5. PERFORMANCE TEST PROCEDURES. (CONT)

CHART 2-8
 Glide Slope Modulation Performance Test
 (Sheet 2 of 2)

TEST EQUIPMENT

Modulation Analyzer HP8901A
 Distortion Analyzer C41-334A

TEST SETUP

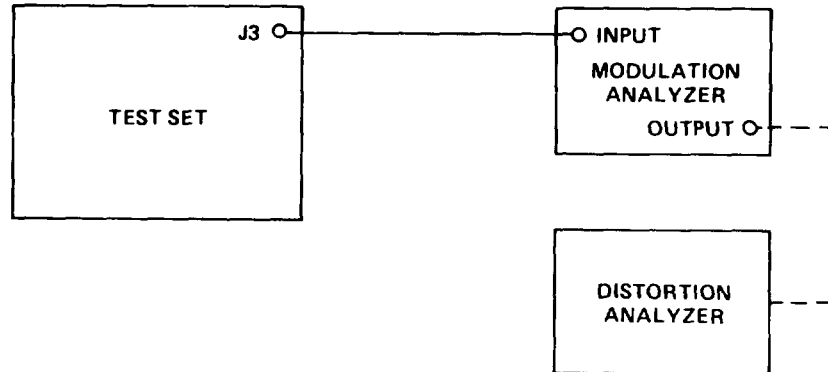

EL9MA039

Test set control settings are same as at the end of LOC DDM Performance Test, except as indicated below.

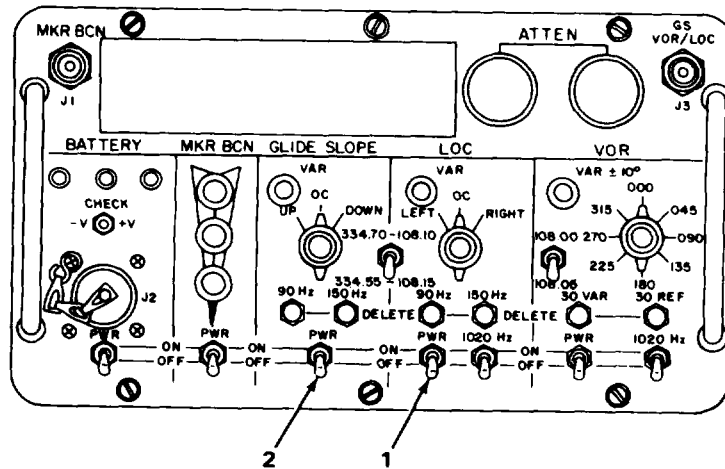

EL9MA045

| KEY | CONTROL/SWITCH | POSITION/SETTING |
|-----|------------------------|------------------|
| 1 | LOC PWR switch | OFF |
| 2 | GLIDE SLOPE PWR switch | ON |

2-5 PERFORMANCE TEST PROCEDURES. (CONT)

CHART 2-9
Glide Slope DDM Performance Test
(Sheet 1 of 2)

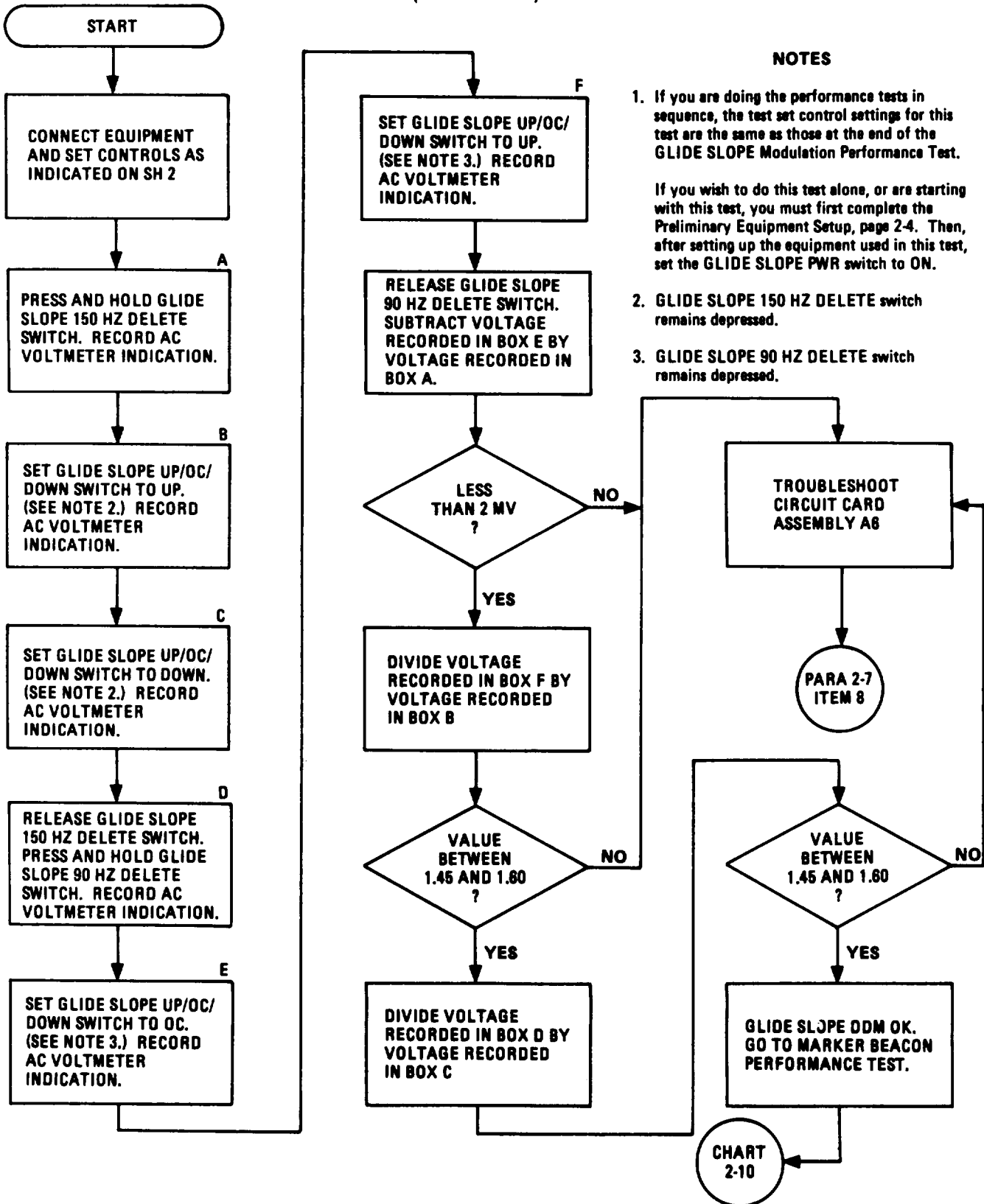

2-5. PERFORMANCE TEST PROCEDURES. (CONT)

CHART 2-9

Glide Slope DDM Performance Test
(Sheet 2 of 2)

TEST EQUIPMENT

Voltmeter HP3490A

TEST SETUP

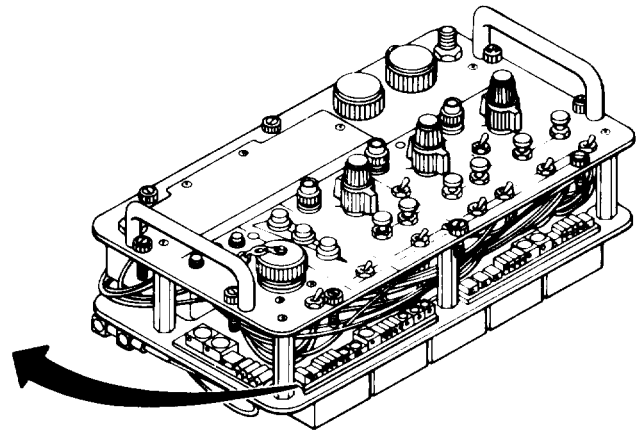
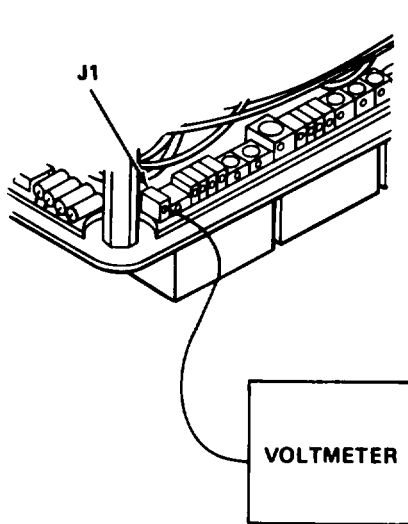

EL9MA046

2-5. PERFORMANCE TEST PROCEDURES. (CONT)

CHART 2-10
Marker Beacon Performance Test
(Sheet 1 of 4)

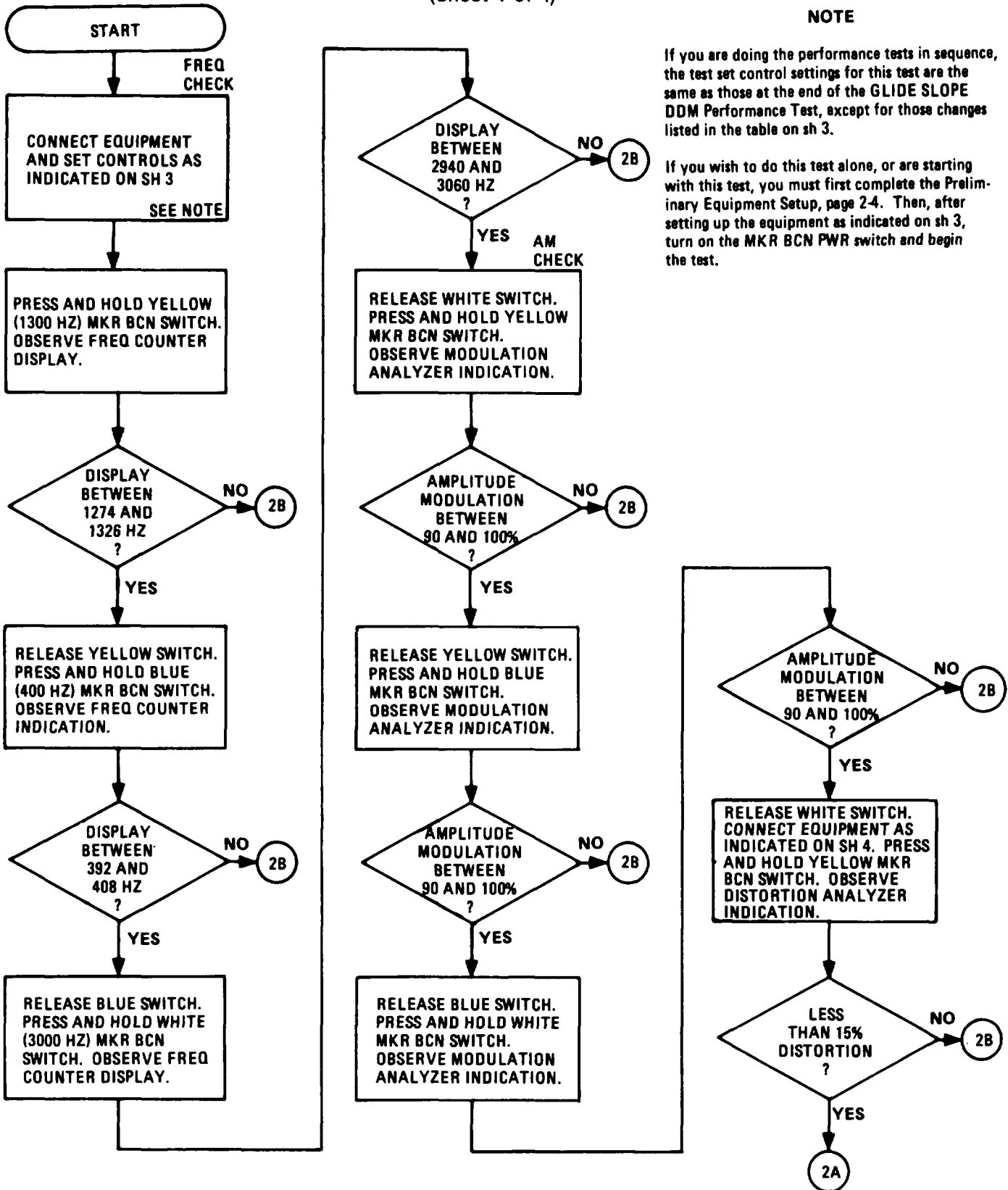

2-5. PERFORMANCE TEST PROCEDURES. (CONT)

CHART 2-10
Marker Beacon Performance Test
(Sheet 2 of 4)

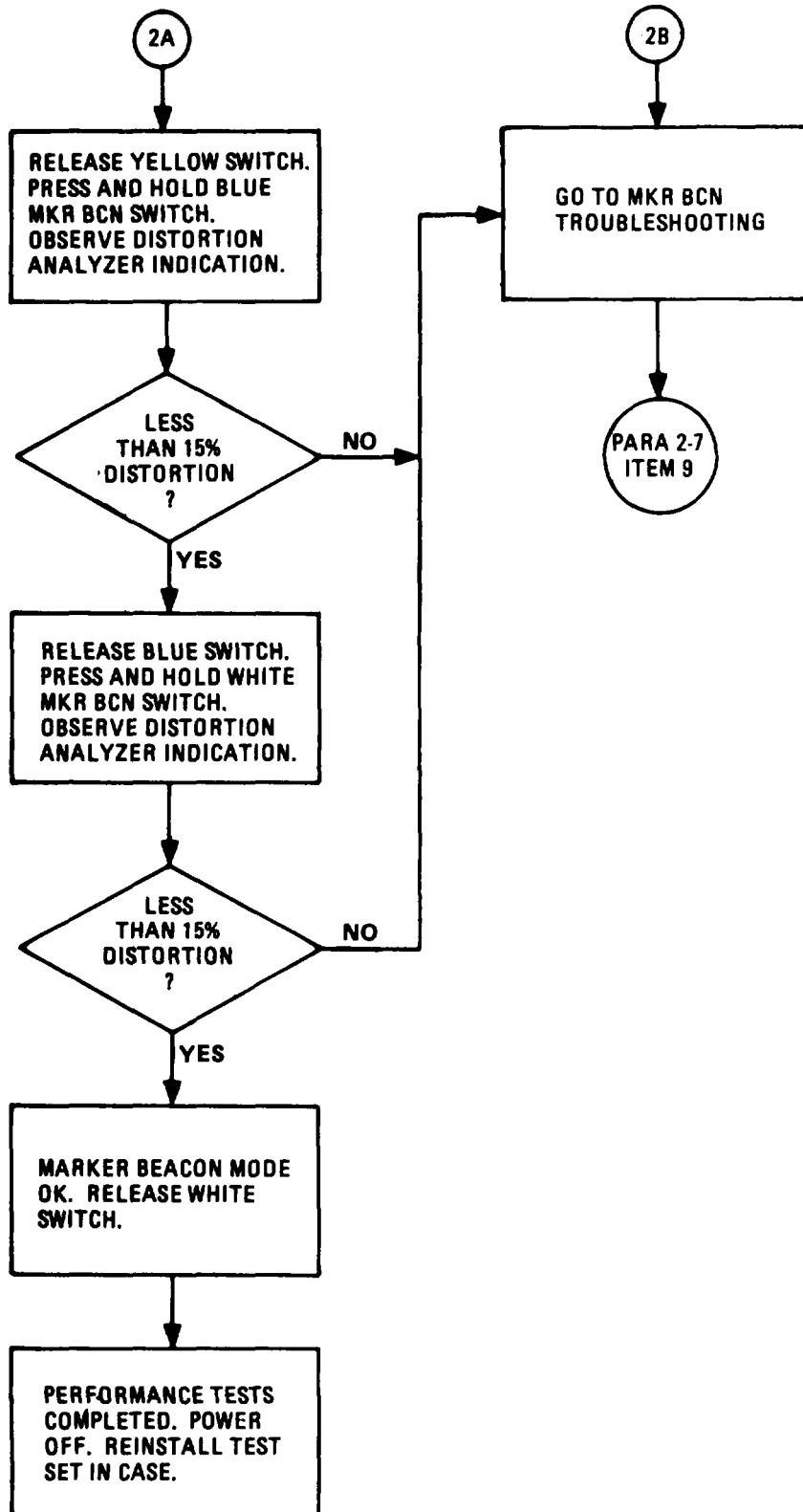

2-5. PERFORMANCE TEST PROCEDURES. (CONT)

CHART 2-10
 Marker Beacon Performance Test
 (Sheet 3 of 4)

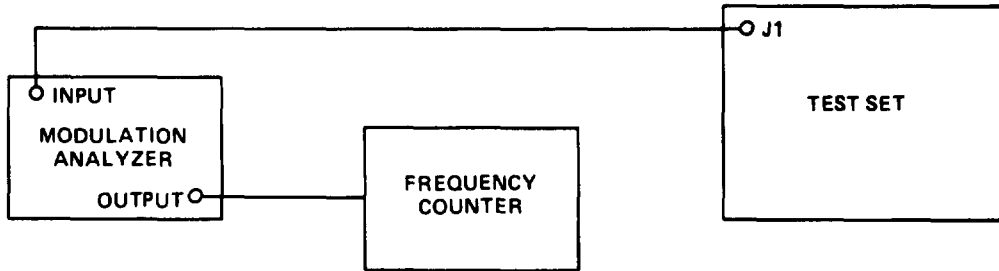

EL9MA047

CONTROL AND SWITCH SETTINGS

Test set control settings are same as at end of GLIDE SLOPE DDM Performance Test, except as indicated below.

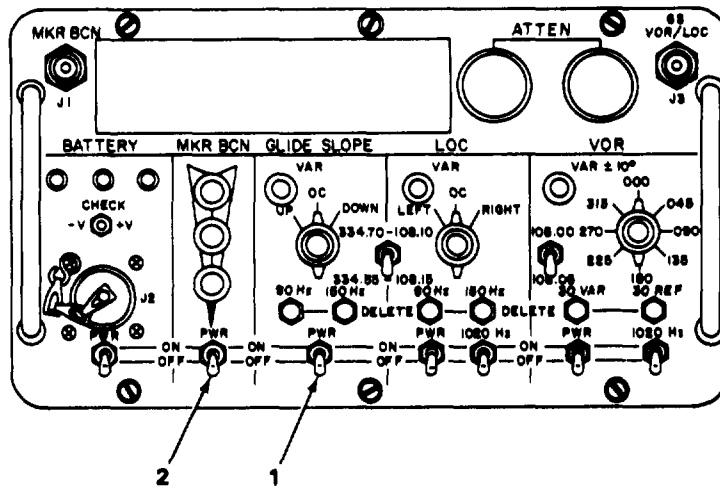

EL9MA048

| KEY | CONTROL/SWITCH | POSITION/SETTING |
|-----|------------------------|------------------|
| 1 | GLIDE SLOPE PWR switch | OFF |
| 2 | MKR BCN PWR switch | ON |

2-5. PERFORMANCE TEST PROCEDURES. (CONT)

CHART 2-10
Marker Beacon Performance Test
(Sheet 4 of 4)

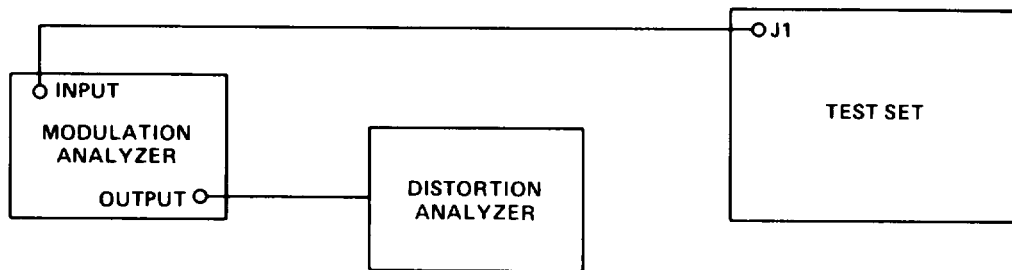

EL9MA049

2-5. PERFORMANCE TEST PROCEDURES. (CONT)

CHART 2-11
Battery Charger Performance Test
(Sheet 1 of 2)

NOTE

Make sure negative lead is connected to pin C.

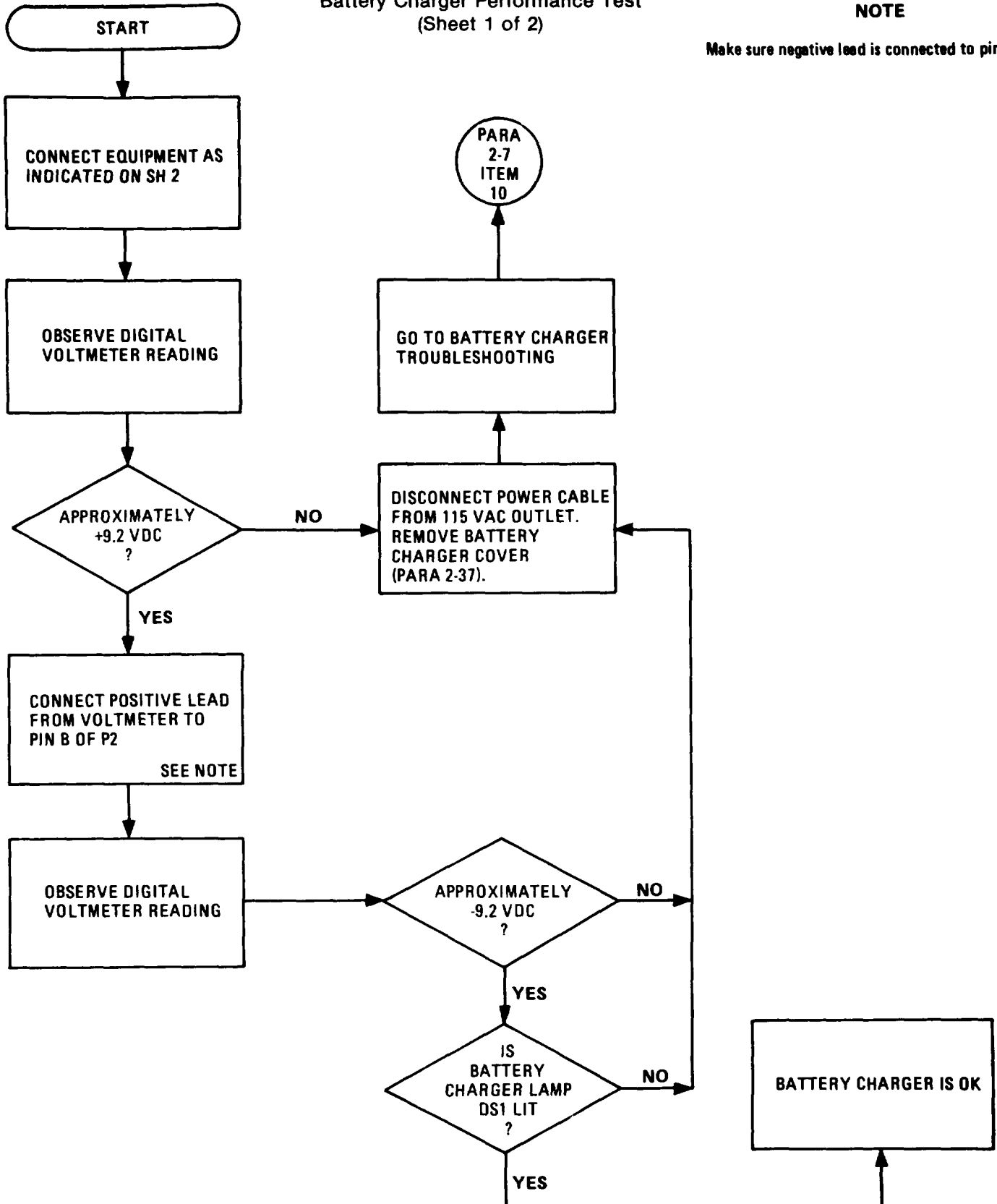

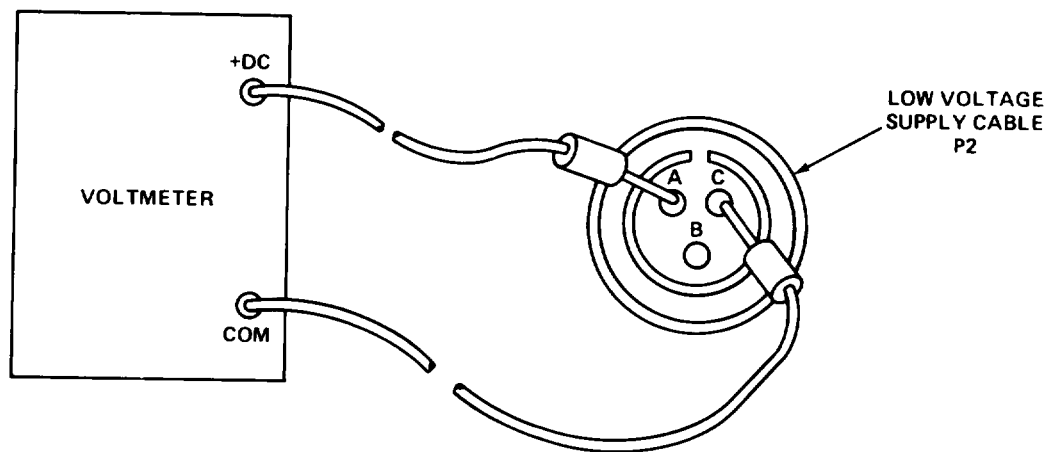
2-5. PERFORMANCE TEST PROCEDURES. (CONT)**CHART 2-11
Battery Charger Performance Test
(Sheet 2 of 2)****TEST EQUIPMENT****Digital Voltmeter HP3490A****TEST SETUP**

EL9MA088

1. Connect battery charger to 115 vac outlet.
2. Connect COM (negative) lead from digital voltmeter to pin C and + DC (positive) lead to pin A of supply cable P2.

Section III TROUBLESHOOTING

| Subject | Para | Page |
|----------------------------|------|------|
| General..... | 2-8 | 2-39 |
| Troubleshooting Table..... | 2-7 | 2-34 |

2-6. GENERAL.

This section contains a troubleshooting table which will help you diagnose faults in the test set. The troubleshooting table is designed to isolate faults in response to specific performance problems noted during performance testing in section 1 of this chapter.

The troubleshooting table does not isolate every possible defect. If you are unable to find the reason for a performance test failure, refer the test set to a higher level of maintenance.

2-7. TROUBLESHOOTING TABLE.

The troubleshooting table is used in the following manner.

1. Go to MALFUNCTION item number referred to in performance test.
2. Perform TEST OR inspection step 1.
3. if CORRECTIVE ACTION is taken, repeat performance test (para 2-5).
4. if no CORRECTIVE ACTION is taken, go to next step.
5. Repeat procedure. Do all steps in sequence.

| MALFUNCTION | TEST OR INSPECTION | CORRECTIVE ACTION |
|-------------|--------------------|-------------------|
|-------------|--------------------|-------------------|

1. No frequency or no power at output.

Step 1. Check coaxial cable connections between appropriate rf module and antenna jack (FO-2). If ok, go to step 2.

Replace defective cables. Tighten loose connections. Recouple bad connections.

Step 2. Check voltage at P1 XTAL pin inputs to appropriate rf module (FO-3).

If voltage is correct, replace rf module (para 2-18).

NOTE

If checking GS mode, replace GS/UHF rf module A2 and repeat performance test. If problem still exists, replace GS/VHF rf module A3.

If checking MB mode, replace MB rf module A1 and repeat performance test. If problem still exists, replace MB impedance Matching Network A7.

2-7. TROUBLESHOOTING TABLE. (CONT)

MALFUNCTION

TEST OR INSPECTION

CORRECTIVE ACTION

-
- Step 3. Check voltage at P20 XTAL and PWR pins to the appropriate rf module (FO-3).
 If voltage is ok, replace circuit card assembly A6 (para 2-19).
 If voltage is Incorrect, go to step 4.
- Step 4. Check appropriate switches for malfunctions (FO-3).
 Replace defective switches.
- Step 5. Check chassis wiring for a short or open circuits (FO-3).
 Repair or replace faulty wiring.
2. incorrect carrier frequency at output.
- Step 1. No check.
 Replace appropriate rf module (para 2-18).
3. Low power at output.
- Step 1. Check for loose coaxial cable connection between appropriate rf module, attenuator, and antenna jack (FO-2).
 Tighten any loose connections.
- Step 2. Check alinement of front panel ATTEN controls (para 2-15).
 Realign misaligned ATTEN controls.
- Step 3. No check.
 Replace appropriate rf module (para 2-18). If checking GS or MB mode, see note under MALFUNCTION 1, step 2.
4. VOR modulation or 9960 fm deviation performance test failure.
- Step 1. Test master oscillator output in the following manner.
 Connect oscilloscope (time base:.01 us; vertical: 1v/div; sync: INT) to J5 (FO-4). Verify ac signal 1 v peak-to-peak min. Connect frequency counter to J5. Verify frequency 3.9322 MHz \pm 400 Hz.
 If voltage or frequency is incorrect, replace circuit card assembly A6 (para 2-19).

2-7. TROUBLESHOOTING TABLE. (CONT)

MALFUNCTION

TEST OR INSPECTION

CORRECTIVE ACTION

4. VOR modulation or 9960 fm deviation performance test failure. (Cont)

Step 2. Test frequency divider output in the following manner.

Connect oscilloscope (time base: 5 ms; vertical: 2v/div; sync: INT) to J16 (FO-4). Verify square wave, 0(base) to 7 (peak) v \pm 1 v amplitude.

Connect frequency counter to J16. Verify frequency 240 ± 0.024 Hz. Connect oscilloscope to J6 (FO-4). Verify square wave, 0(base) to 6.2 (peak) v ± 0.3 v amplitude.

Connect frequency counter to J6. Verify frequency 60 ± 0.006 Hz.

Connect oscilloscope to J17 (FO-4). Verify square wave, 0 (base) to 6.2 (peak) v ± 0.3 v amplitude.

Connect frequency counter to J17. Verify frequency 30×0.003 Hz.

If waveforms, voltages, or frequencies are incorrect, replace circuit card assembly A6.

Step 3. Check VOR modulation adjustment (para 2-11).

Adjust VOR section of circuit card assembly A6 (para 2-11).

If unable to align, or if test set fails performance test after adjustment, replace circuit card assembly A6.

5. VOR zero performance test failure.

Step 1. If error is 45 degrees or more, perform VOR bearing selector alignment (para 2-14).

Step 2. Check setting of A6R72.

With equipment set up as in performance test, adjust A6R72 (FO-4) for 000.00 indication on zifor.

Step 3. If performance test indicates fault still exists, go to MALFUNCTION item 4, step 3.

6. LOC or glide slope modulation performance test failure.

Step 1. Perform steps 1 and 2 under MALFUNCTION item 4.

Step 2. If percent MOD is incorrect, see paragraphs 2-9 and 2-10.

2-7. TROUBLESHOOTING TABLE. (CONT)

| MALFUNCTION | TEST OR INSPECTION | CORRECTIVE ACTION |
|--|---|---|
| | Step 3. Check circuit card assembly A6 alinement. | Adjust appropriate (LOC or GS) section of circuit card assembly A6 (para 2-9 or 2-10). If unable to adjust, or if test set fails performance test after adjustment, replace circuit card assembly A6. |
| 7. LOC DDM performance test failure. | Step 1. Check setting of A6R30 (FO-4). | Connect voltmeter to A6J2. Adjust A6R30 for minimum indication on voltmeter. |
| | Step 2. If performance test indicates fault still exists, follow troubleshooting procedures under MALFUNCTION item 6. | |
| 8. Glide slope DDM performance test failure. | Step 1. Check setting of A6R37 (FO-4). | Connect voltmeter to A6J1. Adjust A6R37 for minimum indication on voltmeter. |
| | Step 2. If performance test indicates fault still exists, follow troubleshooting procedures under MALFUNCTION item 6. | |
| 9. Marker beacon performance test failure. | Step 1. Check setting of A6R110 (FO-4). | Connect modulation analyzer, INPUT to test set and modulation analyzer OUTPUT to frequency counter. Press and hold yellow (1300 Hz) pushbutton, while adjusting A6R110 until frequency counter display is as close as possible to 1300 Hz. |
| | Step 2. Check setting of A6R119 (FO-4). | With equipment connected as indicated in step 1 and yellow pushbutton depressed, adjust A6R119 until modulation analyzer indicates 95% amplitude modulation. If necessary, repeat procedure with other MKR BCN pushbutton depressed. |

2-7. TROUBLESHOOTING TABLE. (CONT)

MALFUNCTION

TEST OR INSPECTION

CORRECTIVE ACTION

9. Marker beacon performance test failure. (Cont)

Step 3. Check circuit card assembly A6 alinement.

Realign A6R110 and A6R1 19, using test points in marker beacon section of circuit card assembly A6 adjustment procedures (para 2-12). If unable to adjust, replace circuit card assembly A6 (para 2-19).

10. Battery charger performance test failure.

Step 1. Check for 115 vac input voltage at points 2 and 3 on transformer T1 (FO-8).

If 115 vac is not present, replace battery charger power cable (para 2-41). if 115 vac is present and lamp DS1 is not lit, replace lamp DS1 (para 2-40).

Step 2. Check for 23 vac at points 5 and 6 on circuit card A1 (FO-8).

if 23 vac is not present, replace transformer T1 (para 2-38).

Step 3. Check for +9.2 vdc at point E1 on circuit card A1 (FO-8).

Adjust R3 on circuit card A1 for +9.2 vdc. if R3 does not adjust to +9.2 vdc, replace circuit card A1 (para 2-39).

Step 4. Check for -9.2 vdc at point E2 on circuit card A1 (FO-8).

Adjust R4 on circuit card A1 for -9.2 vdc, if R4 does not adjust to -9.2 vdc, replace circuit card A1 (para 2-39).

Step 5. Check wiring for continuity and proper connections on supply cable (FO-8).

Replace low-voltage supply cable (para 2-42).

Section IV ALINEMENT PROCEDURES

| Subject | Para | Page |
|--|------|------|
| General | 2-8 | 2-39 |
| LOC Mode Adjustment | 2-9 | 2-39 |
| GS Mode Adjustment | 2-10 | 2-42 |
| VOR Mode Adjustment | 2-11 | 2-45 |
| MB Mode Adjustment | 2-12 | 2-50 |
| Operating Voltage Adjustment | 2-13 | 2-52 |
| VOR Bearing Selector Control Alinement | 2-14 | 2-55 |
| ATTEN Control Alinement | 2-15 | 2-57 |

2-8. GENERAL.

Alinement of circuit card assembly A6 at the general support level consists of partial electronic adjustments of specific mode sections. These adjustments maybe performed individually or as a group, in any order.

Complete alinement of circuit card assembly A6 as well as alinement of the five rf modules are performed at the next higher level of maintenance.

Three of the test set front panel controls (bearing selector knob and two ATTEN control knobs) may be alined electromechanically. These procedures appear in the last two paragraphs of this section.

PRELIMINARY EQUIPMENT SETUP

Before beginning any alinement procedure, perform the preliminary equipment setup beginning on page 2-4.

Test equipment is listed in each procedure as required.

Tool Kit, Electronic Equipment TK-101/G contains all required tools.

No procedure requires more than one technician.

2-9. LOC MODE ADJUSTMENT.

TEST EQUIPMENT REQUIRED

Digital Voltmeter, HP 3490A
 Dual-Volt Power Supply, HP PS503A
 Modulation Analyzer, HP 8901A

EQUIPMENT SETUP

Connect voltmeter to A6J2 as indicated in the following diagram.

NOTE

Dual-volt power supply connection shown in preliminary procedure (pages 2-5 and 2-6).

2-9. LOC MODE ADJUSTMENT. (CONT)

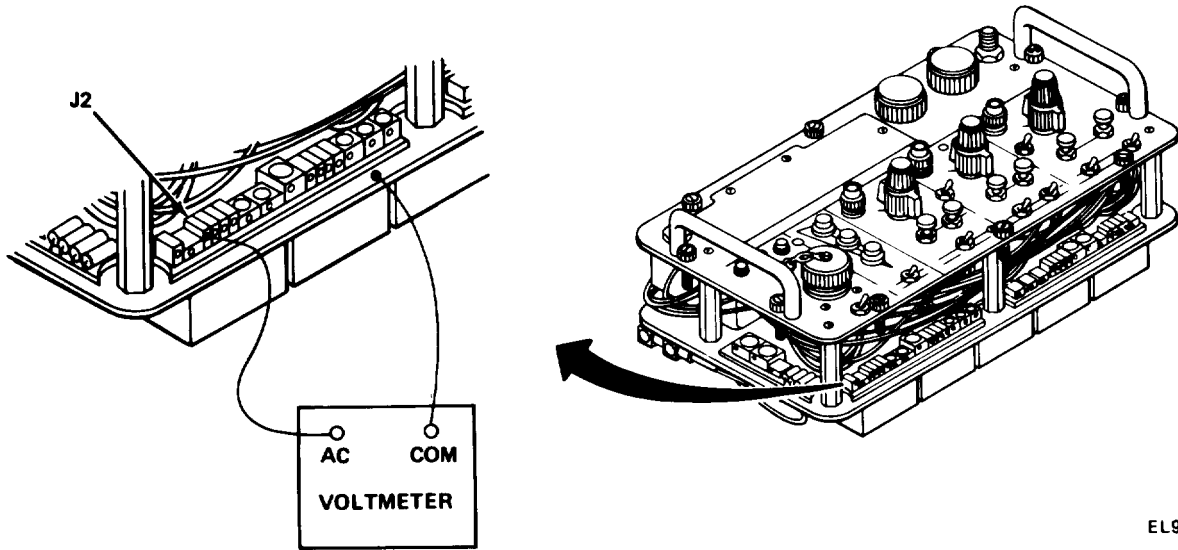

EL9MA050

CONTROL AND SWITCH SETTINGS

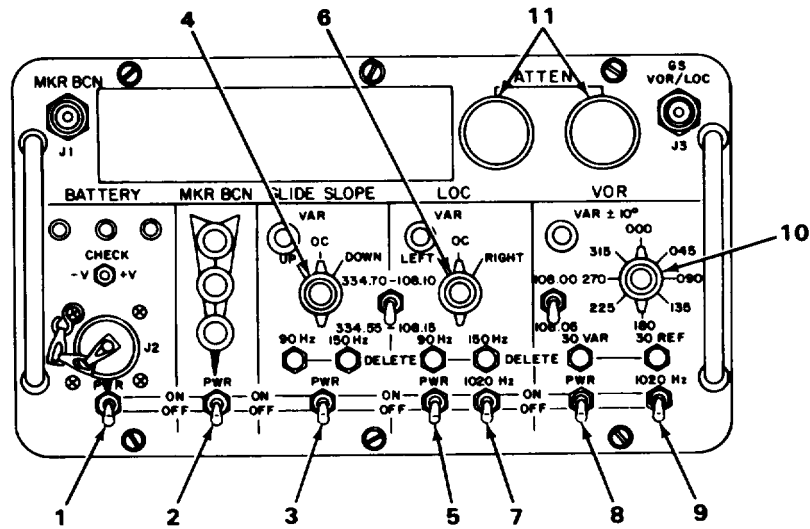

EL9MA051

Set test set controls as indicated in the following table.

| KEY | CONTROL/SWITCH | POSITION/SETTING |
|-----|------------------------|------------------|
| 1 | BATTERY PWR | ON |
| 2 | MKR BCN PWR | OFF |
| 3 | GLIDE SLOPE PWR | OFF |
| 4 | GLIDE SLOPE UP/OC/DOWN | ANY |
| 5 | LOC PWR | ON |
| 6 | LOC LEFT/OC/RIGHT | OC |

2-9. LOC MODE ADJUSTMENT. (CONT)

| KEY | CONTROL/SWITCH | POSITION/SETTING |
|-----|-----------------------|------------------|
| 7 | LOC 1020 HZ | OFF |
| 8 | VOR PWR | OFF |
| 9 | VOR 1020 HZ | OFF |
| 10 | VOR bearing | ANY |
| 11 | ATTEN controls (both) | 0 |

NOTE

If any VAR lamp is flashing, press to extinguish.

PROCEDURE

1. Press and hold LOC 150 HZ DELETE switch. Record voltmeter indication.
2. Release LOC 150 HZ DELETE switch.
3. Press and hold LOC 90 HZ DELETE switch. Record voltmeter indication.
4. Add value recorded in step 3 to value recorded in step 1.
5. Divide result of step 4 computation by 2.

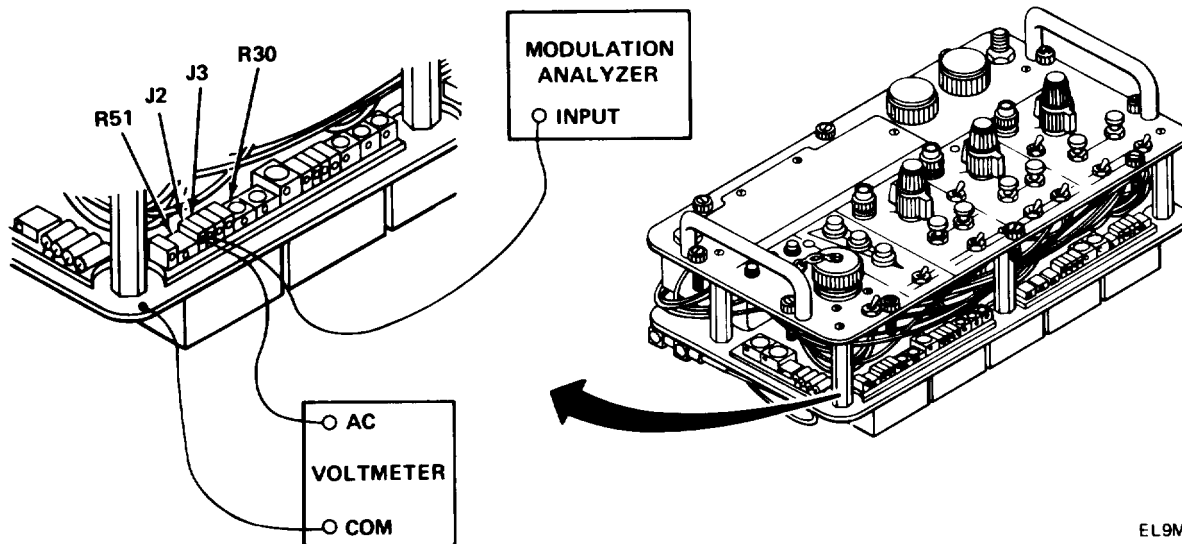

EL9MA052

6. With LOC 90 HZ DELETE switch depressed, adjust R30 until voltmeter indication equals average computed in step 5 \pm 10 mv.
7. Release LOC 90 HZ DELETE switch.
8. Alternately press (and release) LOC 150 HZ and 90 HZ DELETE switches, while readjusting R30 until voltmeter indicates 150 Hz level within 1 mv of 90 Hz level.
9. Disconnect voltmeter and connect modulation analyzer to J3.
10. Press and hold 150 HZ DELETE switch while adjusting R51 until analyzer indicates \pm 20 percent MOD.
11. Release LOC 150 HZ DELETE switch.
12. Disconnect modulation analyzer.

2-10. GS MODE ADJUSTMENT.

TEST EQUIPMENT REQUIRED

Digital Voltmeter, HP 3490A
 Dual-Volt Power Supply, HP PS503A

EQUIPMENT SETUP

Connect equipment as indicated in the following diagram.

NOTE

Dual-volt power supply connection shown in preliminary procedure (pages 2-5 and 2-6).

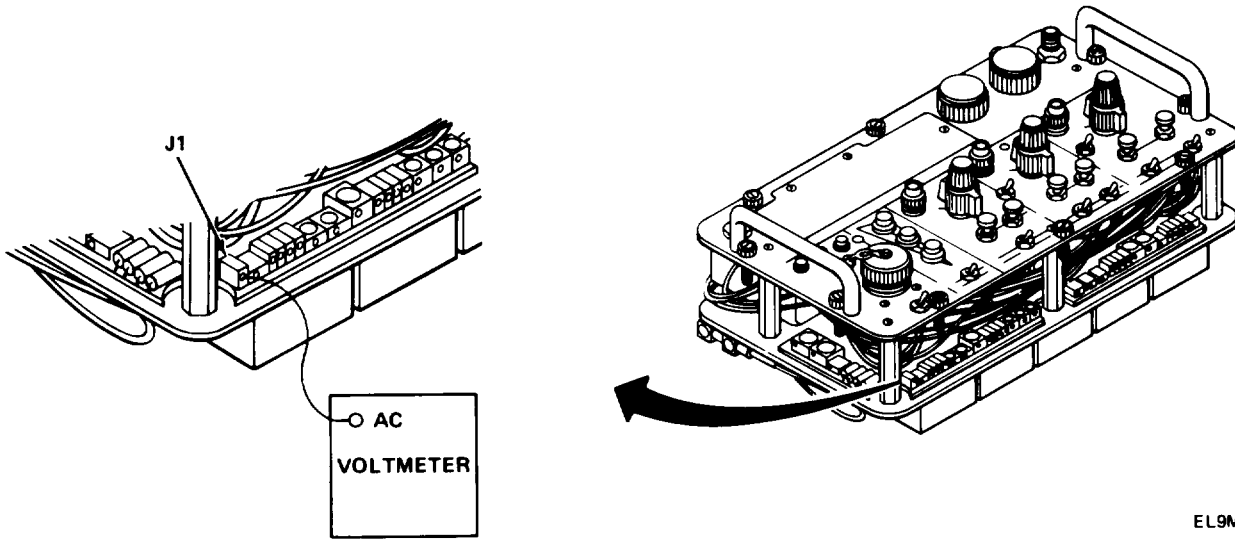

EL9MA053

CONTROL AND SWITCH SETTINGS

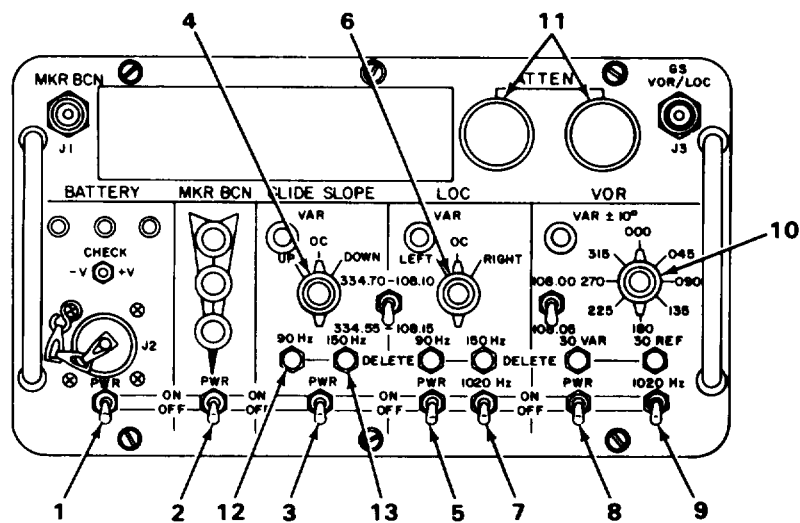

EL9MA054

Set test set controls as indicated in the following table.

2-10. GS MODE ADJUSTMENT. (CONT)

| KEY | CONTROL/SWITCH | POSITION/SETTING |
|-----|------------------------|------------------|
| 1 | BATTERY PWR | ON |
| 2 | MKR BCN PWR | OFF |
| 3 | GLIDE SLOPE PWR | ON |
| 4 | GLIDE SLOPE UP/OC/DOWN | OC |
| 5 | LOC PWR | OFF |
| 6 | LOC LEFT/OC/RIGHT | ANY |
| 7 | LOC 1020 HZ | OFF |
| 8 | VOR PWR | OFF |
| 9 | VOR 1020 HZ | OFF |
| 10 | VOR bearing | ANY |
| 11 | ATTEN controls (both) | 0 |

NOTE

If any VAR lamp is flashing, press to extinguish.

PROCEDURE

1. Press and hold GLIDE SLOPE 90 HZ DELETE switch. Record voltmeter indication.
2. Release GLIDE SLOPE 90 HZ DELETE switch.
3. Press and hold GLIDE SLOPE 150 HZ DELETE switch. Record voltmeter indication.
4. Add value recorded in step 3 to value recorded in step 1.
5. Divide result of step 4 computation by 2.

2-10. GS MODE ADJUSTMENT. (CONT)

PROCEDURE (CONT)

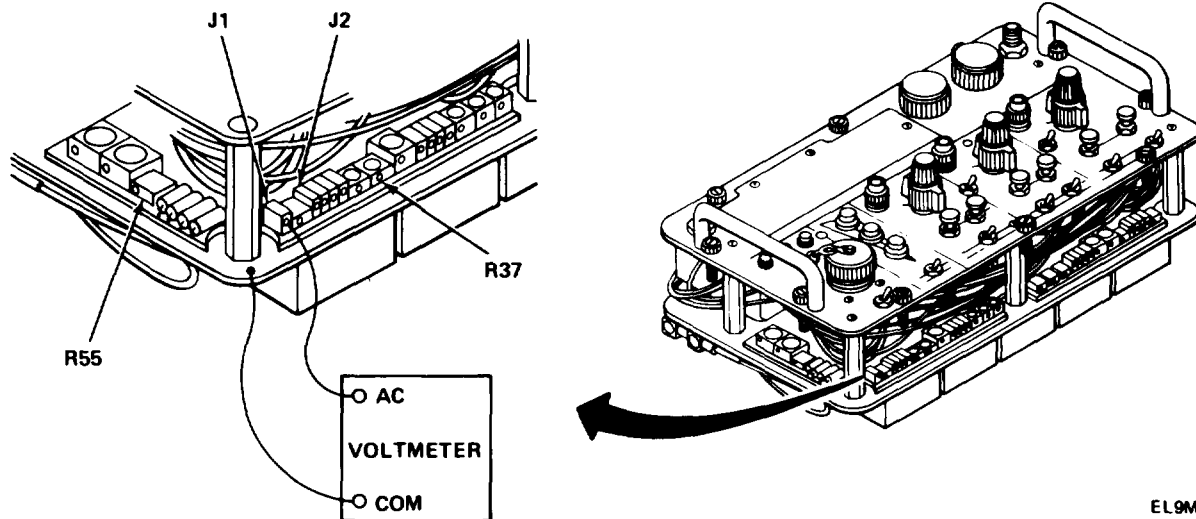

6. With GLIDE SLOPE 150 HZ DELETE switch depressed, adjust R37 until voltmeter indication equals average computed in step 5 ± 10 mv.
7. Release GLIDE SLOPE 150 HZ DELETE switch.
8. Alternately press (and release) GLIDE SLOPE 150 HZ and 90 HZ DELETE switches, while readjusting R37 until voltmeter indicates 90 Hz level within 2 mv of 150 Hz level.
9. Press and hold GLIDE SLOPE 90 HZ DELETE switch.
10. Adjust R55 until voltmeter indicates 300 ± 10 mv.
11. Release GLIDE SLOPE 90 HZ DELETE switch.
12. Disconnect digital voltmeter.

2-11. VOR MODE ADJUSTMENT.

TEST EQUIPMENT REQUIRED

- Dual-Volt Power Supply, HP PS503A
- Oscilloscope, TEK 5440 with plug-ins 5B42 and 5A48
- Digital Voltmeter, HP 3490A
- Frequency Counter, HP 5345A
- Jumper Wire
- Modulation Analyzer, HP 8901A

EQUIPMENT SETUP

Connect digital voltmeter to test set as indicated in the following diagram.

NOTE

Dual-volt power supply connection shown in preliminary procedure (page 2-4).

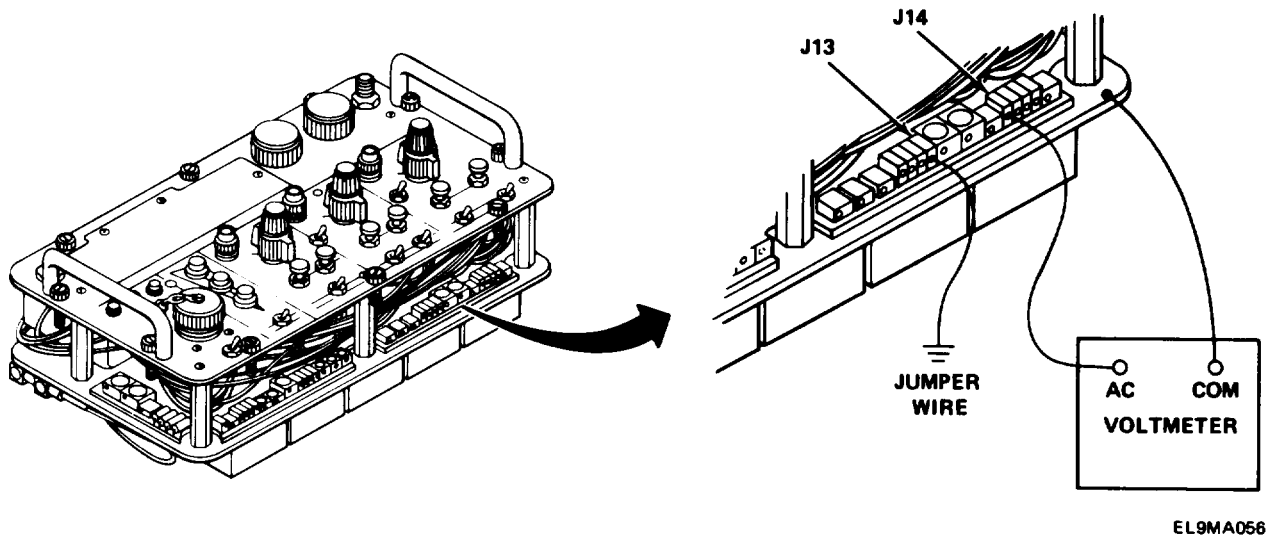

2-11. VOR MODE ADJUSTMENT. (CONT)

CONTROL AND SWITCH SETTINGS

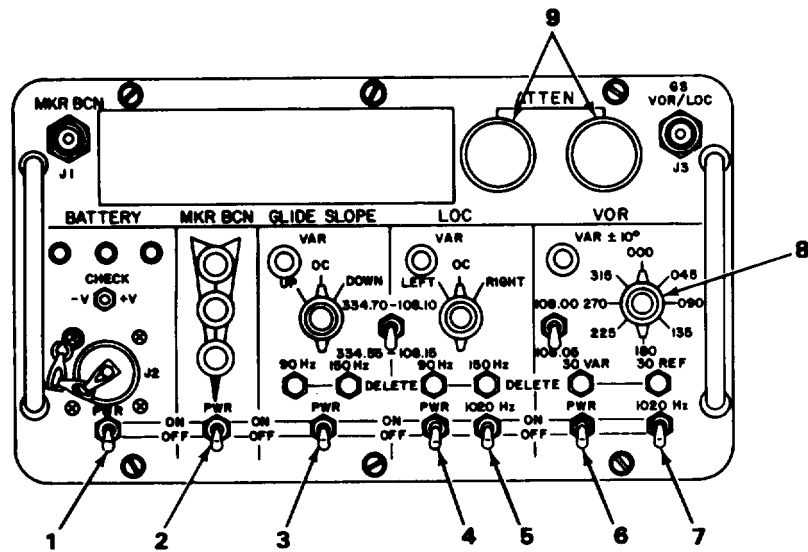

EL9MA033

Set test set controls as indicated in the following table.

| KEY | CONTROL/SWITCH | POSITION/SETTING |
|-----|-----------------------|------------------|
| 1 | BATTERY PWR | ON |
| 2 | MKR BCN PWR | OFF |
| 3 | GLIDE SLOPE PWR | OFF |
| 4 | LOC PWR | OFF |
| 5 | LOC 1020 HZ | OFF |
| 6 | VOR PWR | ON |
| 7 | VOR 1020 HZ | OFF |
| 8 | VOR bearing | 000 ° |
| 9 | ATTEN controls (both) | 0 |

NOTE

If any VAR lamp is flashing, press to extinguish.

2-11. VOR MODE ADJUSTMENT. (CONT)

PROCEDURE

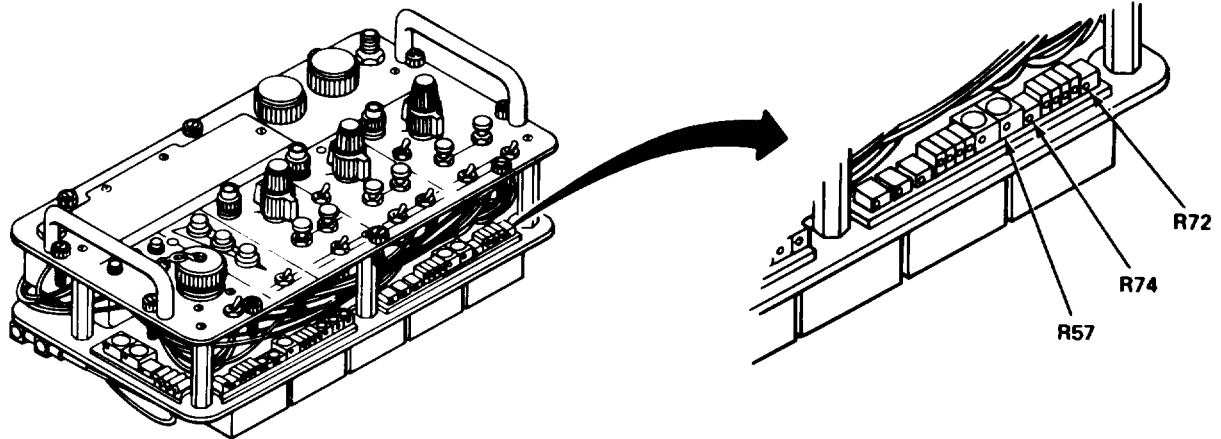

EL9MA057

1. Adjust R74 until voltmeter indicates 160 ± 10 mv.

NOTE

Adjusting R74 will change the voltmeter reading of R72 adjustment and vice versa. Be sure to double check both adjustments after adjusting R72.

2. Adjust R72 until voltmeter indicates 120 ± 10 mv.
3. Set voltmeter mode to DC and connect frequency counter to J12 as shown below.
4. Press 30 HZ REF DELETE switch then adjust R57 for 9960 Hz on frequency counter. The dc meter should indicate between 4.650 and 4.850 vdc.
5. Disconnect voltmeter from test set.

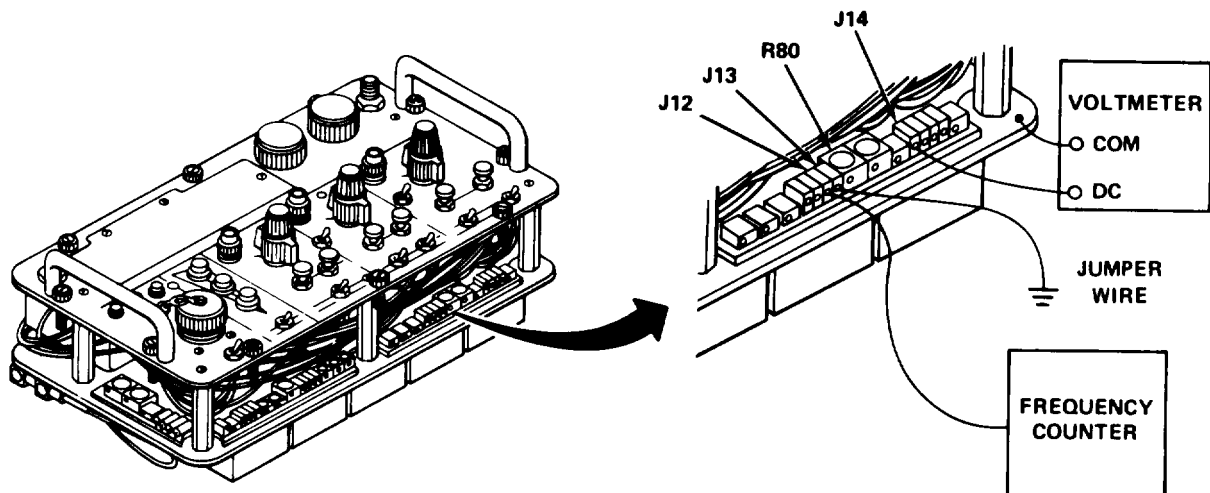

EL9MA058

2-11. VOR MODE ADJUSTMENT. (CONT)

PROCEDURE (CONT)

6. Set oscilloscope controls as follows:

TIME BASE: 0.1 ms/div

VERT: 2v/div

SYNC: INT

7. Connect oscilloscope to test set as indicated in the following diagram.

NOTE

Frequency counter remains connected to J12.

VOR 30 REF DELETE switch remains depressed until step 15.

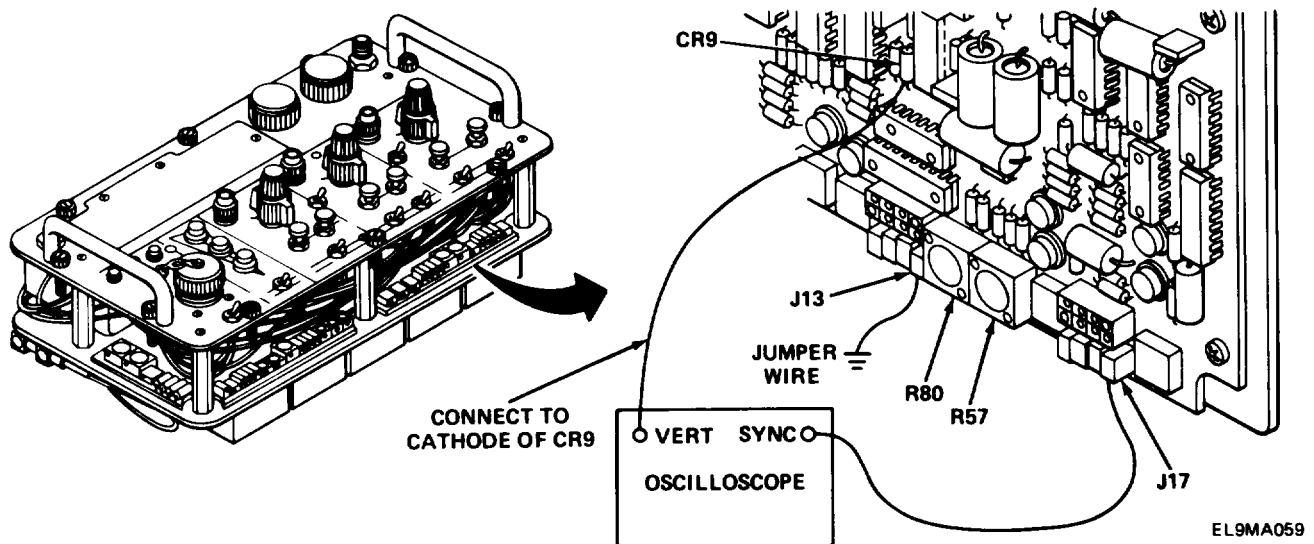

8. Adjust R80, if needed, to produce a symmetrical square wave with base at zero v and peak at +6 v.
9. Readjust R57 until frequency counter displays 9960 Hz \pm .004.
10. Remove jumper form J13.

2-11. VOR MODE ADJUSTMENT. (CONT)

11. Connect modulation analyzer to J3 of test set.

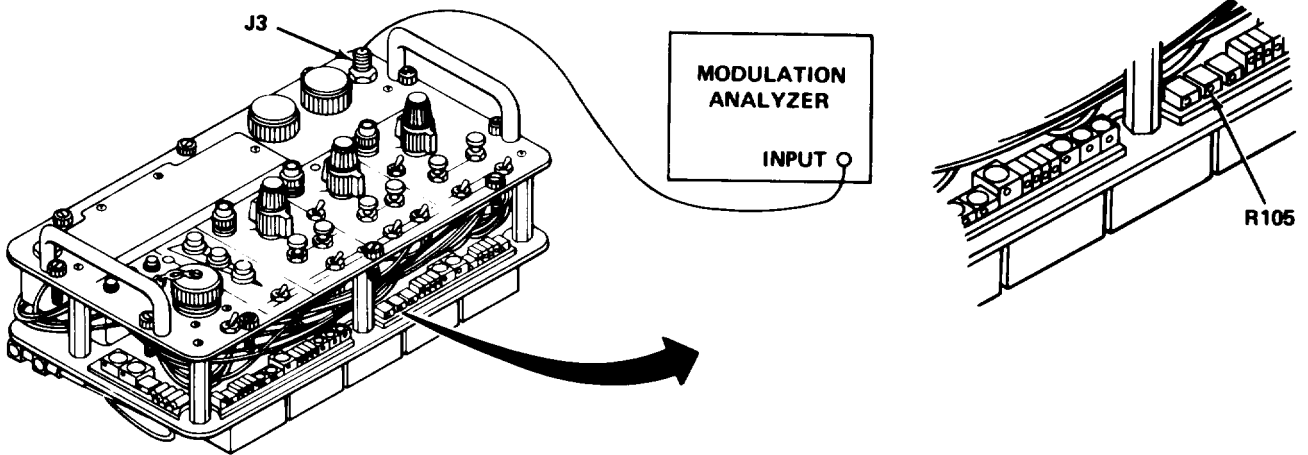

EL9MA060

12. Press and hold VOR 30 VAR and 30 REF DELETE switches while adjusting R105 until modulation analyzer indicates between 359.30 and 000.7.
13. Release 30 VAR DELETE and 30 REF DELETE switches.

2-12. MB MODE ADJUSTMENT.

TEST EQUIPMENT REQUIRED

- Dual-Volt Power Supply, HP PS503A
- Frequency Counter, HP 5345A
- Modulation Analyzer, HP 8901A
- Digital oitmeter, HP 3490A

EQUIPMENT SETUP

Connect equipment as indicated in the following diagram.

NOTE

Dual-volt power supply connection shown in preliminary procedure (page 2-4).

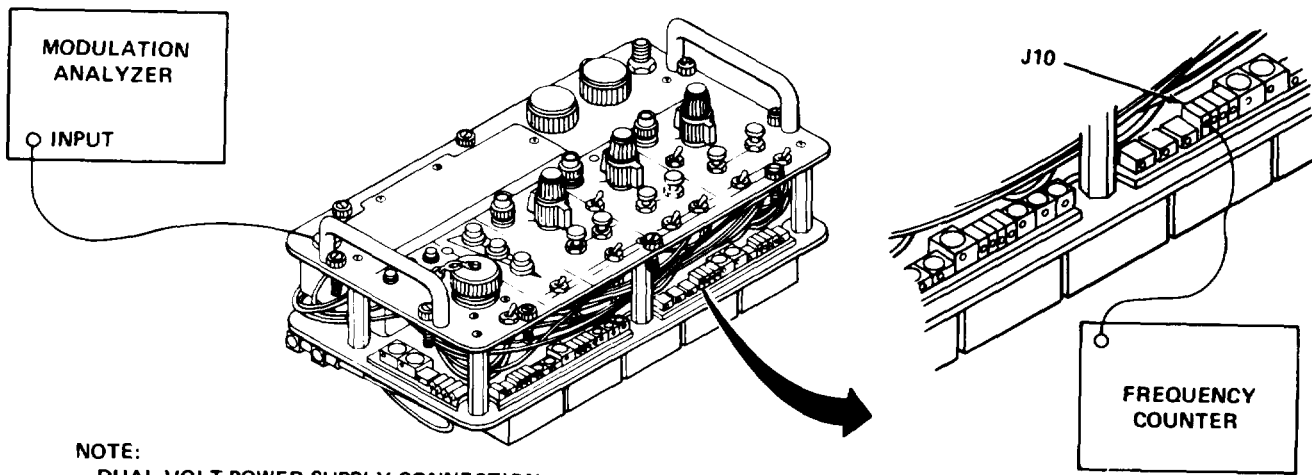

NOTE:
DUAL VOLT POWER SUPPLY CONNECTION
SHOWN IN PRELIMINARY PROCEDURE
ON PAGES 2-5 AND 2-6.

EL9MA061

CONTROL AND SWITCH SETTINGS

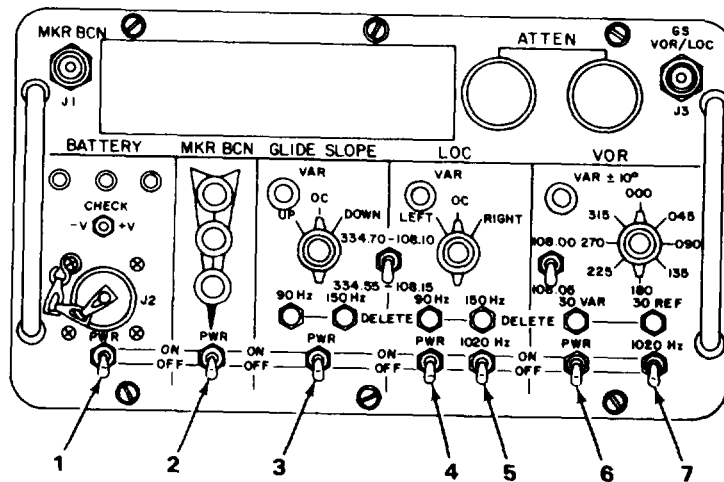

EL9MA062

2-12. MB MODE ADJUSTMENT (CONT)

Set test set controls as indicated in the following table.

| KEY | CONTROL/SWITCH | POSITION/SETTING |
|-----|-----------------|------------------|
| 1 | BATTERY PWR | ON |
| 2 | MKR BCN PWR | ON |
| 3 | GLIDE SLOPE PWR | ON |
| 4 | LOC PWR | OFF |
| 5 | LOC 1020 HZ | OFF |
| 6 | VOR PWR | OFF |
| 7 | VOR 1020 HZ | OFF |

NOTE

If any VAR lamp is flashing, press to extinguish.

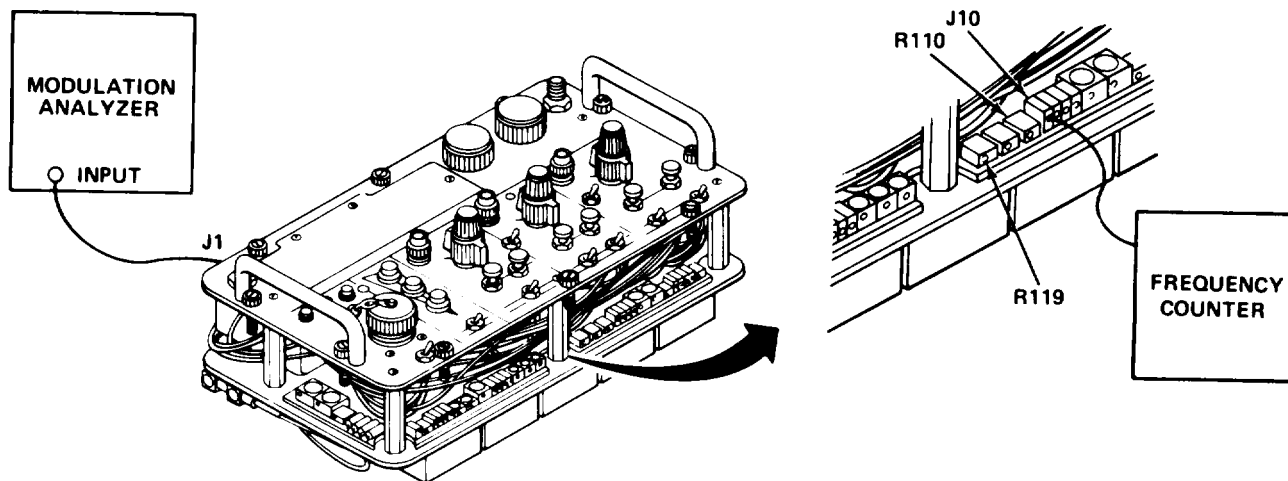

EL9MA063

1. Press and hold yellow (1300) MKR BCN switch.
2. Adjust R110 until frequency counter displays 1300 ± 26 Hz.
3. Adjust R119 until modulation analyzer indicates 95 ± 4.75 percent modulation.
4. Release yellow MKR BCN switch.

2-13. OPERATING VOLTAGE ADJUSTMENT.

TEST EQUIPMENT REQUIRED

Dual-Volt Power Supply, HP 5345A
Digital Voltmeter, HP 3490A

EQUIPMENT SETUP

Connect equipment as indicated in the following diagram.

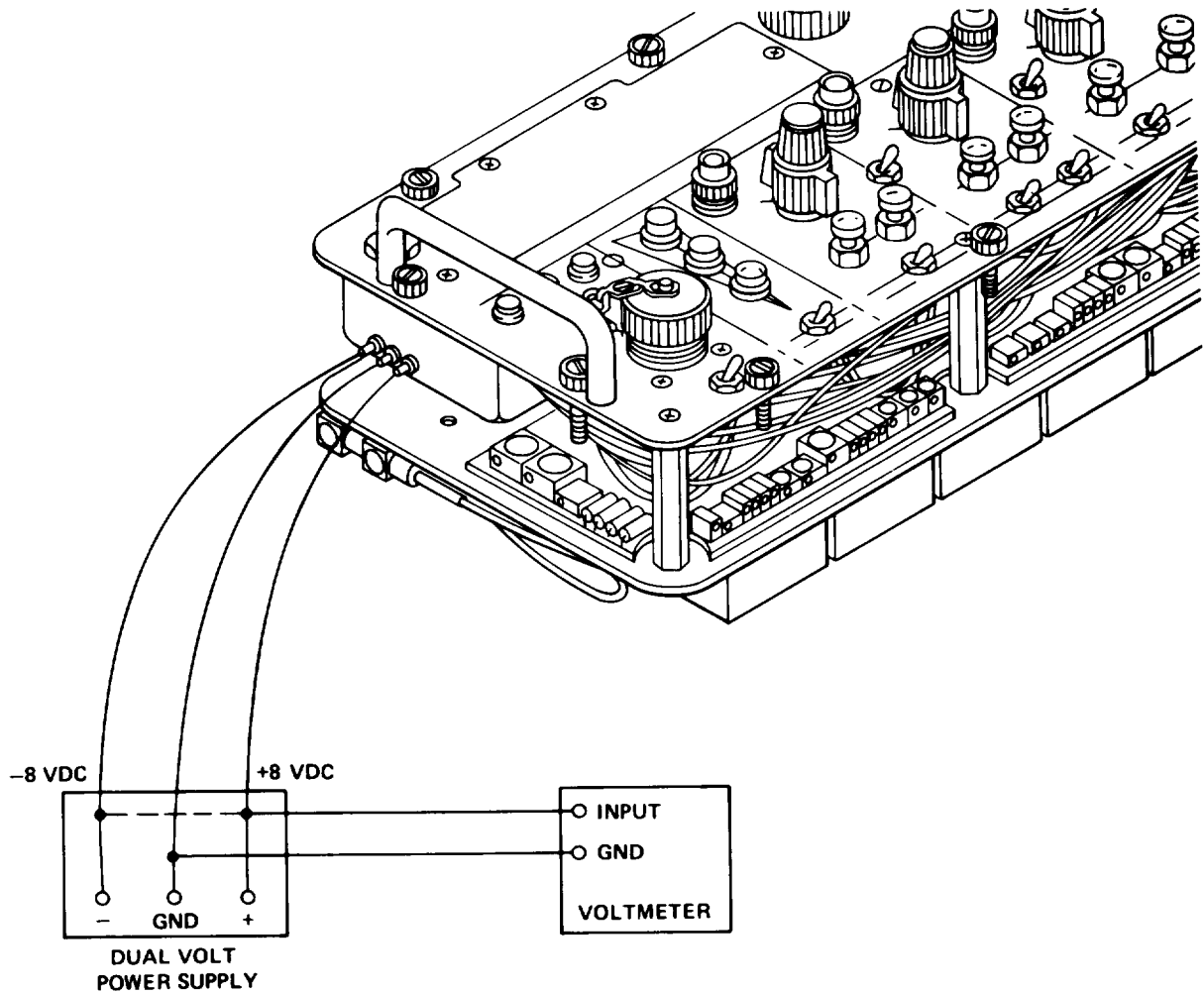

EL9MA080

2-13. OPERATING VOLTAGE ADJUSTMENT. (CONT)

CONTROL AND SWITCH SETTINGS

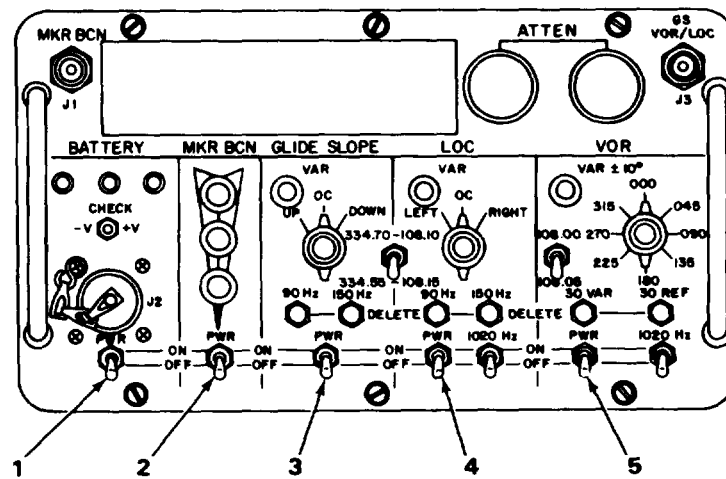

EL9MA064

| KEY | CONTROL/SWITCH | POSITION/SETTING |
|-----|-----------------|------------------|
| 1 | BATTERY PWR | ON |
| 2 | MKR BCN PWR | OFF |
| 3 | GLIDE SLOPE PWR | OFF |
| 4 | LOC PWR | OFF |
| 5 | VOR PWR | OFF |

NOTE

If any VAR lamp is flashing, press to extinguish.

PROCEDURE

1. Reduce power supply positive voltage until voltmeter indicates + 7.750 vdc ±1 mv.
2. Set and hold BATTERY CHECK switch in +V position.

2-13. OPERATING VOLTAGE ADJUSTMENT. (CONT)

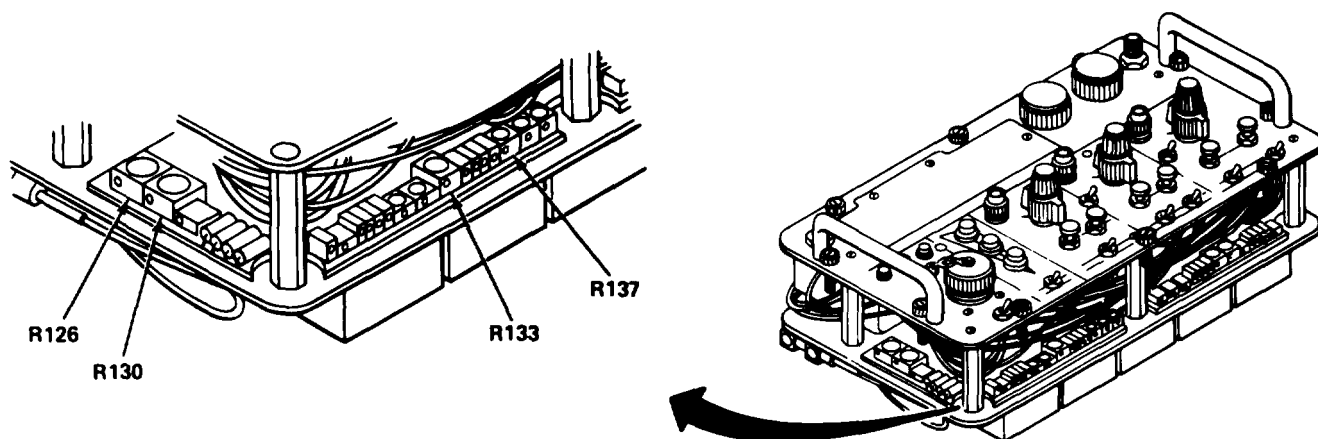

EL9MA065

3. Adjust R130 until green lamp goes out and amber lamp lights.
4. Increase positive power supply voltage to +7.752 vdc.
5. If necessary, readjust R130 until amber lamp goes off and green lamp lights.
6. Reduce positive power supply voltage to +7.748 vdc.
7. If necessary, readjust R130 until green lamp goes off and amber lamp lights.
8. Repeat procedure until lamps change from green to amber when positive power supply voltage is reduced to $+7.750 \text{ v} \pm 1 \text{ mv dc}$.
9. Reduce positive power supply voltage to $+7.200 \text{ v} \pm 1 \text{ mv dc}$.
10. Adjust R126 until amber lamp goes out and red lamp lights.
11. Increase positive power supply voltage to +7.202 vdc.
12. If necessary, readjust R126 until red lamp goes off and amber lamp lights.
13. Reduce positive power supply voltage to +7.196 vdc.
14. If necessary, readjust R126 until amber lamp goes off and red lamp lights.
15. Repeat procedure until lamps change from amber to red when positive power supply is reduced to $7.200 \text{ v} \pm 1 \text{ mv dc}$.
16. Set positive power supply voltage to +8.000 vdc.
17. Reduce negative power supply voltage to $-7.750 \text{ v} \pm 1 \text{ mv dc}$.
18. Set and hold BATTERY CHECK switch in -V position.
19. Adjust R133 until green lamp goes out and amber lamp lights.
20. Increase negative power supply voltage to -7.752 vdc.
21. If necessary, readjust R133 until amber lamp goes off and green lamp lights.
22. Reduce negative power supply voltage to -7.748 vdc.
23. If necessary, readjust R133 until green lamp goes off and amber lamp lights.
24. Repeat procedure until lamps change from green to amber when negative power supply voltage is reduced to $-7.750 \text{ v} \pm 1 \text{ mv dc}$.
25. Reduce negative power supply voltage to $-7200 \text{ v} \pm 1 \text{ mv dc}$.
28. Adjust R137 until amber lamp goes out and red lamp lights.
27. Increase negative power supply voltage to -7.202 vdc.
28. If necessary, readjust R137 until red lamp goes off and amber lamp lights.
29. Reduce negative power supply voltage to -7.198 vdc.
30. If necessary, readjust R137 until amber lamp goes off and red lamp lights.
31. Repeat procedure until lamps change from amber to red when negative power supply is reduced to $7.200 \text{ v} \pm 1 \text{ mv dc}$.
32. Release BATTERY CHECK switch.

2-14. VOR BEARING SELECTOR CONTROL ALINEMENT.

TEST EQUIPMENT REQUIRED

Oscilloscope, TK 5440 with plug-ins 5B42 and 5A48
 Dual-Volt Power Supply, HP PS503A

EQUIPMENT SETUP

Connect equipment as Indicated In the following diagram.

NOTE

Dual-volt power supply connection shown in preliminary procedure (page 2-4).

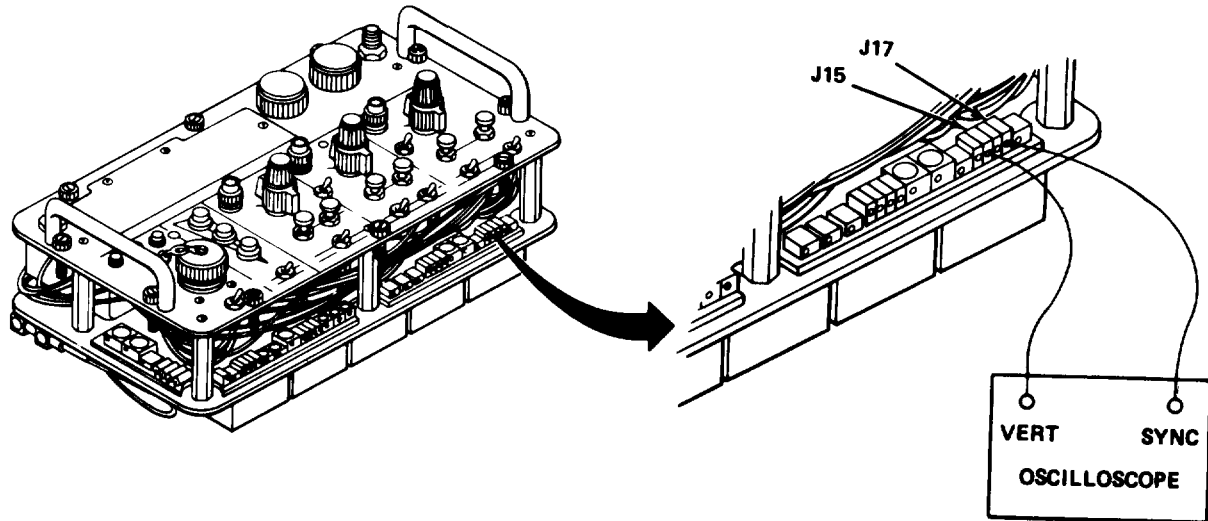

EL9MA066

CONTROL AND SWITCH SETTINGS

Set oscilloscope controls as follows.
 TIME BASE: 2 ms/div
 VERT: 2 v/div
 SYNC: EXT

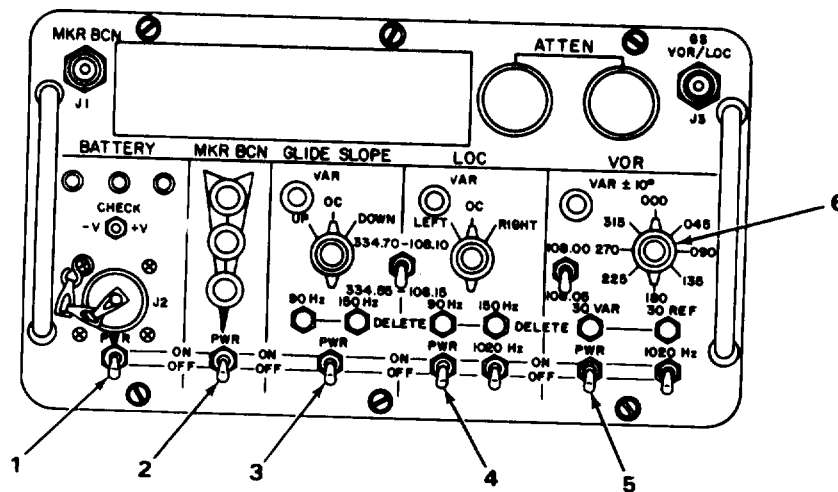

EL9MA081

Set test set controls as indicated in the following table.

2-14. VOR BEARING SELECTOR CONTROL ALINEMENT. (CONT)

| KEY | CONTROL/SWITCH | POSITION/SETTING |
|-----|----------------------|------------------|
| 1 | BATTERY PWR | ON |
| 2 | MKR BCN PWR | OFF |
| 3 | GLIDE SLOPE PWR | OFF |
| 4 | LOC PWR | OFF |
| 5 | VOR PWR | ON |
| 6 | VOR bearing selector | 000° |

NOTE

If any VAR lamp is flashing, press to extinguish.

PROCEDURE

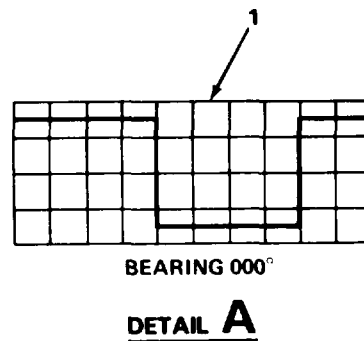
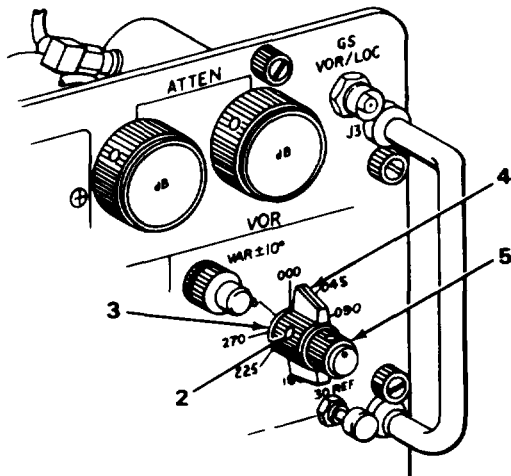

EL9MA067

1. Adjust oscilloscope TIME BASE variable control and rotate VOR bearing selector control until oscilloscope display matches detail A (1).
2. Loosen two setscrews (2) on VOR bearing selector control (3).
3. Lineup control index mark(4) with front panel 000° display.

NOTE

Do not loosen setscrew on variable (inside) control (5).

4. Retighten two setscrews (2) and verify that oscilloscope waveform still matches detail A (1).

2-14. VOR BEARING SELECTOR CONTROL ALINEMENT. (CONT)

PROCEDURE (CONT)

NOTE

Make sure control VOR bearing selector control does not touch front panel.

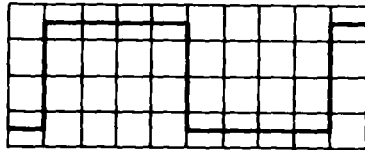

BEARING 045°

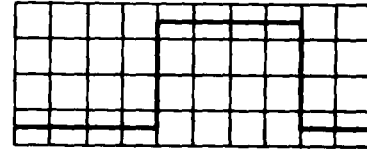

BEARING 180°

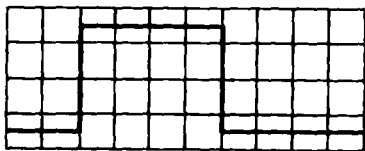

BEARING 090°

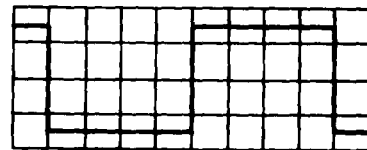

BEARING 225°

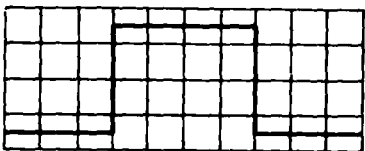

BEARING 135°

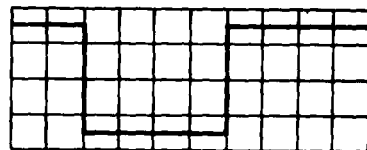

BEARING 270°

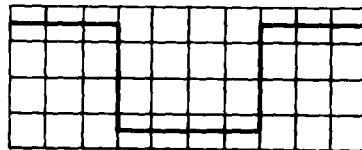

BEARING 315°

EL9MA088

4. Rotate VOR bearing selector control clockwise, stopping at each control setting. Verify oscilloscope waveform at each control setting matches appropriate square wave in diagram above.

2-15. ATTEN CONTROL ALINEMENT.

TEST EQUIPMENT REQUIRED

Dual-Volt Power Supply, HP PS503A
 Power Meter, HP 432A with H75-478A

EQUIPMENT SETUP

Connect equipment as indicated in the following diagram.

NOTE

Dual-volt power supply to test set J2 pin connections shown in preliminary procedure (page 24).

2-15. ATTEN CONTROL ALINEMENT. (CONT)

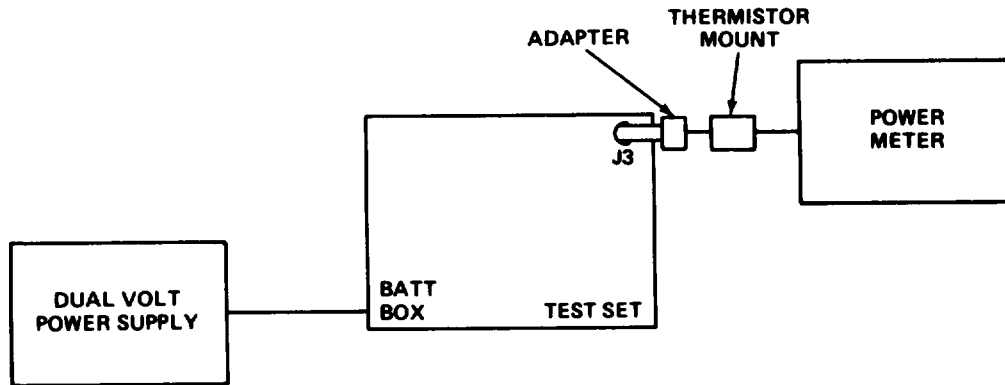

EL9MA069

CONTROL AND SWITCH SETTINGS

Set all power switches on test set to OFF position.

PROCEDURE

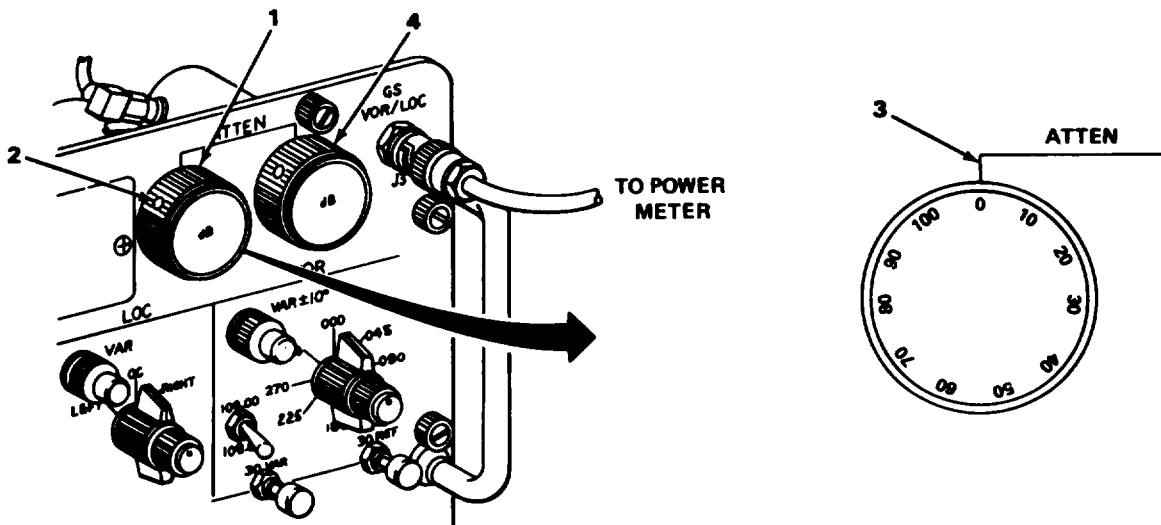

EL9MA071

1. Turn on battery power switch and VOR power.
2. Rotate 10 dB ATTEN control (1) through one complete rotation, then set control (1) at point where power meter indicates maximum output.
3. Loosen setscrews (2) on 10 dB ATTEN control (1) and line up 10 dB ATTEN control 0 display with front panel index mark (3).
4. Retighten two setscrews (2).
5. Verify power meter indicates maximum output with 10 dB ATTEN control (1) set to 0.
6. Rotate 1 dB ATTEN control (4) through one complete rotation, then set control (4) at point where power meter indicates maximum output.
7. Loosen setscrews on 1 dB ATTEN control (4) and line up 1 dB ATTEN control 0 display with front panel index mark.
8. Retighten two setscrews.
9. Verify power meter indicates maximum output with 1 dB ATTEN control (4) set to 0.

Section V MAINTENANCE PROCEDURES

| Subject | Para | Page |
|--|------|------|
| General | 2-16 | 2-59 |
| Electronic Components Assembly Replacement | 2-17 | 2-60 |
| Modules A1 Through A5 Replacement..... | 2-18 | 2-61 |
| A6 and A8 Assembly Replacement..... | 2-19 | 2-62 |
| A6 Circuit Board Assembly Replacement | 2-20 | 2-64 |
| Antenna Jack J1 and J3 Replacement | 2-21 | 2-65 |
| Attenuator Switch AT1 and AT2 Replacement | 2-22 | 2-66 |
| Battery Case Replacement..... | 2-23 | 2-68 |
| TB1 Contact Board Replacement | 2-24 | 2-70 |
| Pushbutton Switch S8, S9, S13, S14, S19, and S20 Replacement..... | 2-25 | 2-71 |
| Toggle Switch S1, S2, S6, S10, S12, S15, S16, S18, S21, and S22 Replacement | 2-26 | 2-72 |
| Pushbutton Switch S23, S24, and S25 Replacement..... | 2-27 | 2-73 |
| Connector J2 Replacement | 2-28 | 2-74 |
| Indicator Light DS1, DS2, and DS3 Replacement..... | 2-29 | 2-75 |
| Pushbutton Switch S3, S4, and S5 Replacement..... | 2-30 | 2-76 |
| Impedance Matching Network A7 Replacement..... | 2-31 | 2-77 |
| Rotary Switch S7,S11, and S17 Replacement..... | 2-32 | 2-78 |
| Front Panel Replacement | 2-33 | 2-79 |
| Battery Charger Conversion to 230 VAC Operation | 2-34 | 2-80 |
| Painting | 2-35 | 2-80 |
| Placing in Service | 2-36 | 2-80 |
| Battery Charger Cover Replacement..... | 2-37 | 2-81 |
| Battery Charger Transformer T1 Replacement..... | 2-38 | 2-82 |
| Battery Charger Circuit Board AI Replacement | 2-39 | 2-83 |
| Battery Charger Indicator Light DS1 Replacement..... | 2-40 | 2-84 |
| Battery Charger Power Cable Replacement | 2-41 | 2-85 |
| Battery Charger Low Voltage Supply Cable Replacement..... | 2-42 | 2-86 |

2-16. GENERAL.

This section provides instructions for general support maintenance procedures for test set, receiver AN/ARM-186 components. The following setup information applies to all procedures.

Resources required are not listed unless they apply to the particular procedure.

Personnel are listed only if the task requires more than one technician.

The normal equipment condition to start a maintenance task is power supply disconnected and batteries removed (TM 11-6625-2976-12), unless otherwise specified.

All soldering methods must be in accordance with TB SIG 222.

Tool Kit, Electronic Equipment TK-101/G is used for all procedures.

2-17. ELECTRONIC COMPONENTS ASSEMBLY REPLACEMENT.

PRELIMINARY PROCEDURE: Remove batteries. (Refer to TM 11-6625-2976-12).

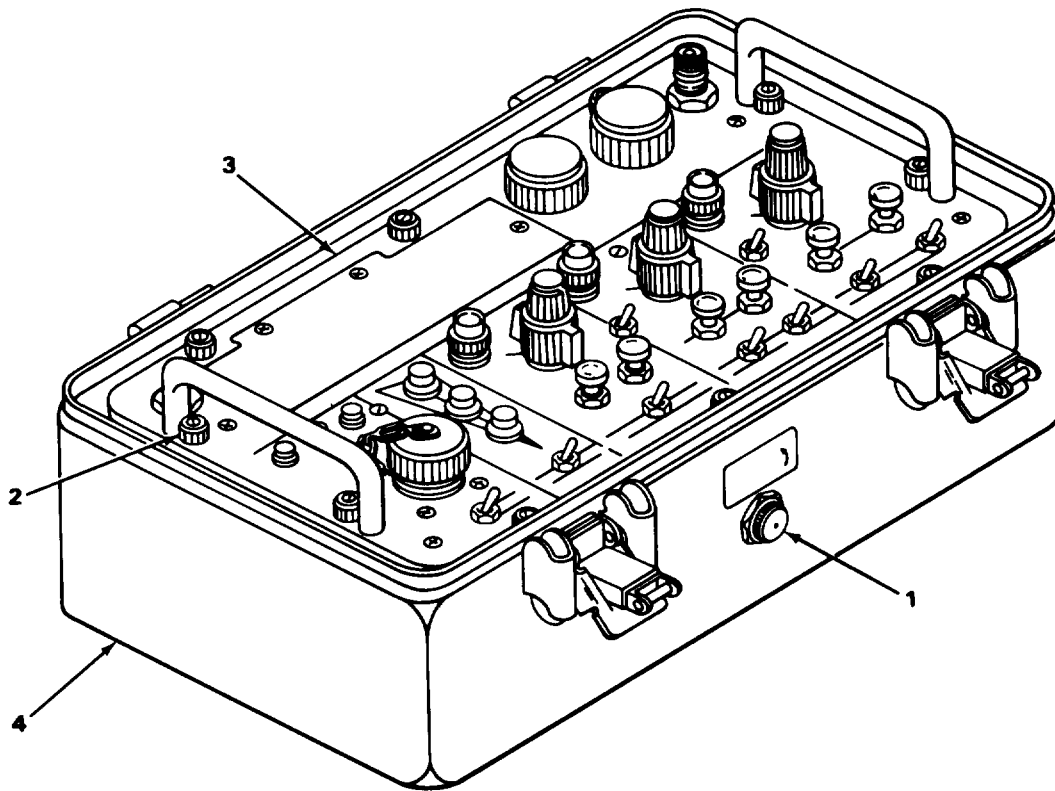

EL9MA016

REMOVAL

1. Turn equalizer knob(1) counterclockwise to open. Allow 5 seconds for pressure to equalize. Leave open.
2. Using screwdriver, loosen 10 captive screws (2).
3. Carefully remove electronic components assembly(3) from case (4).

INSTALLATION

1. Carefully position electronic components assembly(3) in case (4).
2. Using screwdriver, tighten 10 captive screws (2).
3. Turn equalizer knob (1) clockwise to close.

FOLLOW-ON MAINTENANCE: Install batteries. (Refer to TM 11-6625-2976-12.)

2-18. MODULES A1 THROUGH A5 REPLACEMENT.

MATERIALS/PARTS: Marker beacon assembly, A1 (P/N 629-0201-001)
 Uhf glide slope assembly, A2 (P/N 629-0202-001)
 Vhf glide slope assembly, A3 (P/N 629-0203-002)
 Localizer assembly, A4 (P/N 629-0204-002)
 VOR assembly, A5 (P/N 629-0205-001)

PRELIMINARY PROCEDURE: Remove electronic components assembly (para 2-17).

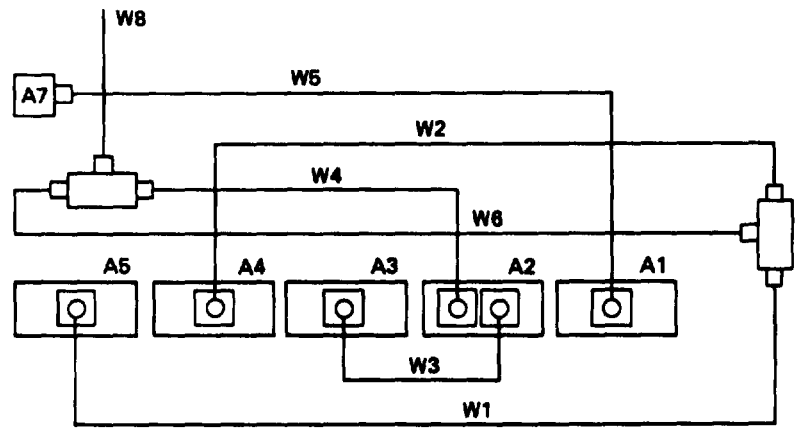
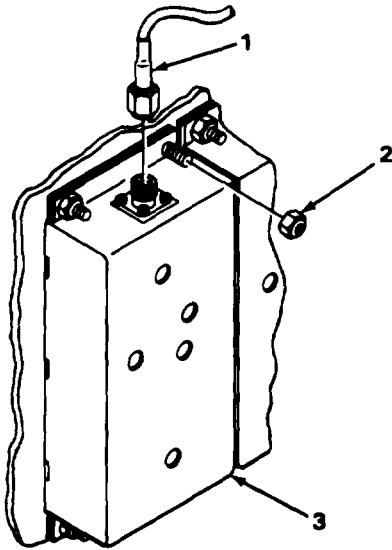

EL9MA017

REMOVAL

NOTE

Steps given are typical for all modules. Module A2 has two rf cable connectors while all other modules have only one rf cable connector.

1. Using wrench, remove rf cable connector (1).
2. Using socket driver, remove four nuts (2).
3. Carefully pull module (3) straight up from board to release from pins.

INSTALLATION

NOTE

Steps given are typical for all modules. Module A2 has two rf cable connectors while all other modules have only one rf cable connector.

See wiring diagram to aid in connector installation.

1. Carefully position module (3) on pins and push into place,
2. Install four nuts(2) and, using socket driver, tighten.
3. Install rf cable connector (1) and, using wrench, tighten.

FOLLOW-ON MAINTENANCE: install electronic components assembly (para 2-17).

2-19. A6 AND A8 ASSEMBLY REPLACEMENT.

PRELIMINARY PROCEDURE: Remove electronic components assembly (para 2-17).

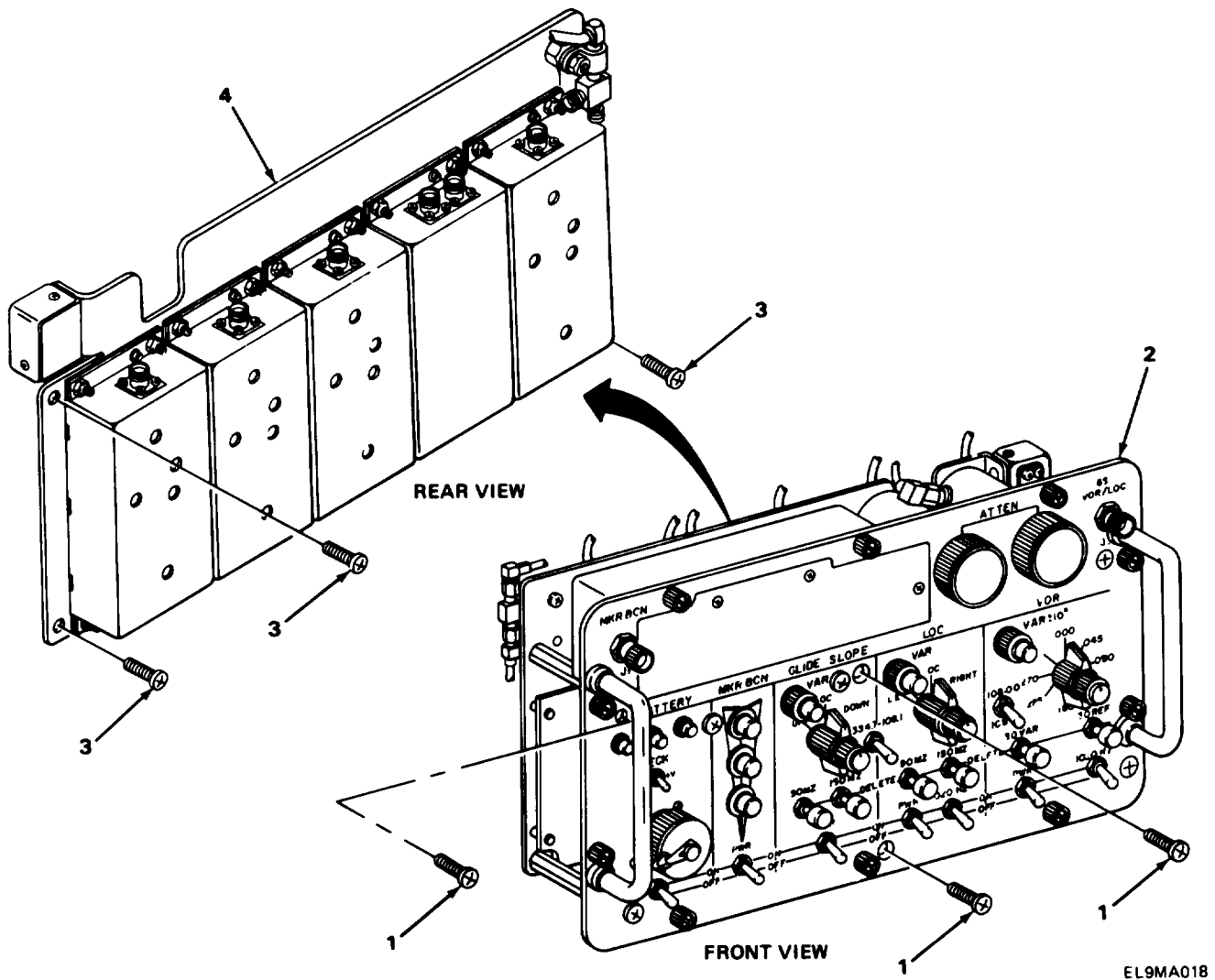

REMOVAL

1. Using screwdriver, remove three screws (1) from front panel (2).
2. Using screwdriver, remove three screws (3) from A6 and A8 assembly (4).

2-19. A6 AND A8 ASSEMBLY REPLACEMENT. (CONT)

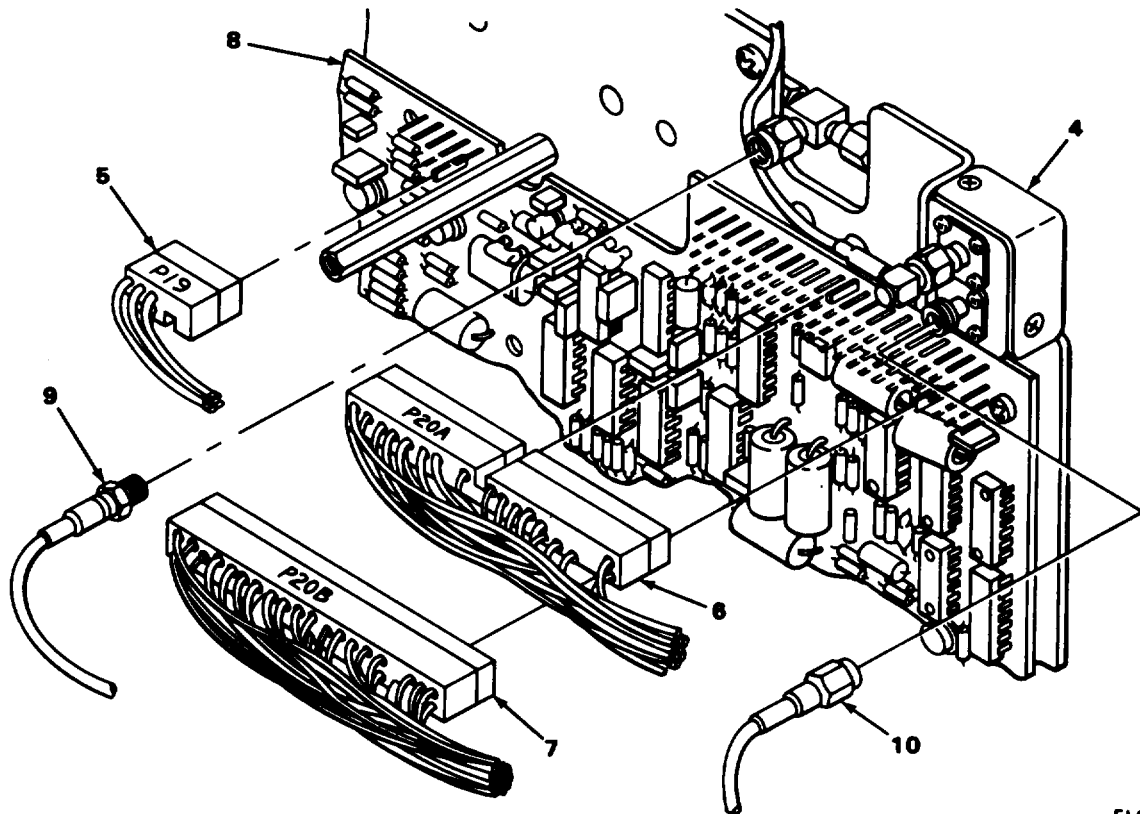

EL9MA019

3. Unplug connectors P19(5), P20A (6), and P20B (7) from A6 circuit board (8).
4. Using wrench, remove rf cable connectors W8(9) and W10(10).
5. Remove A6 and A8 assembly (4) from front panel.

INSTALLATION

1. Position A6 and A8 assembly (4) behind front panel (2).
2. Install rf cable connectors W10 (10) and W8 (9) to A6 circuit board (8) and, using wrench, tighten.
3. Plug connectors P20B (7), P20A (6), and P19 (5) into A6 circuit board (8).
4. Anne A6 and A8 assembly (4) with standoffs on front panel.
5. Install three screws (3) and, using screwdriver, tighten.
6. Install three screws (1) and, using screwdriver, tighten.

FOLLOW-ON MAINTENANCE: Install electronic components assembly(para 2-17).

2-20. A6 CIRCUIT BOARD ASSEMBLY REPLACEMENT.

MATERIALS/PARTS: Circuit board assembly, A6 (P/N 629-0206-001)

PRELIMINARY PROCEDURE: Remove A6 and A8 assembly (para 2-19).

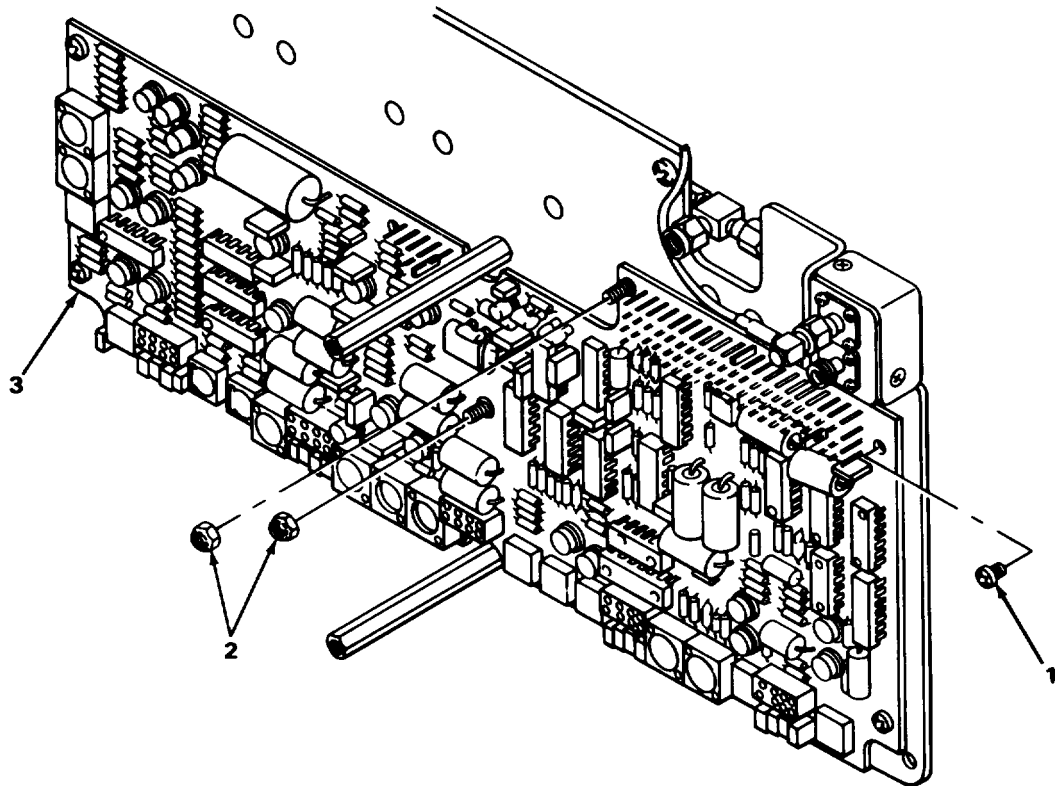

EL9MA020

REMOVAL

1. Using screwdriver, remove four screws (1).
2. Using socket driver, remove two nuts (2).
3. Carefully pull circuit board (3) straight up to release from pins.

INSTALLATION

1. Position circuit board (3) on pins and push into place.
2. Install two nuts (2) and, using socket driver, tighten.
3. Install four screws (1) and, using screwdriver, tighten.

FOLLOW-ON MAINTENANCE: Install A6 and A8 assembly (para 2-19).

2-21. ANTENNA JACK J1 AND J3 REPLACEMENT.

MATERIALS/PARTS: Jack, antenna, electrical, J1 and J3

PRELIMINARY PROCEDURE: Remove A6 and A8 assembly (para 2-19).

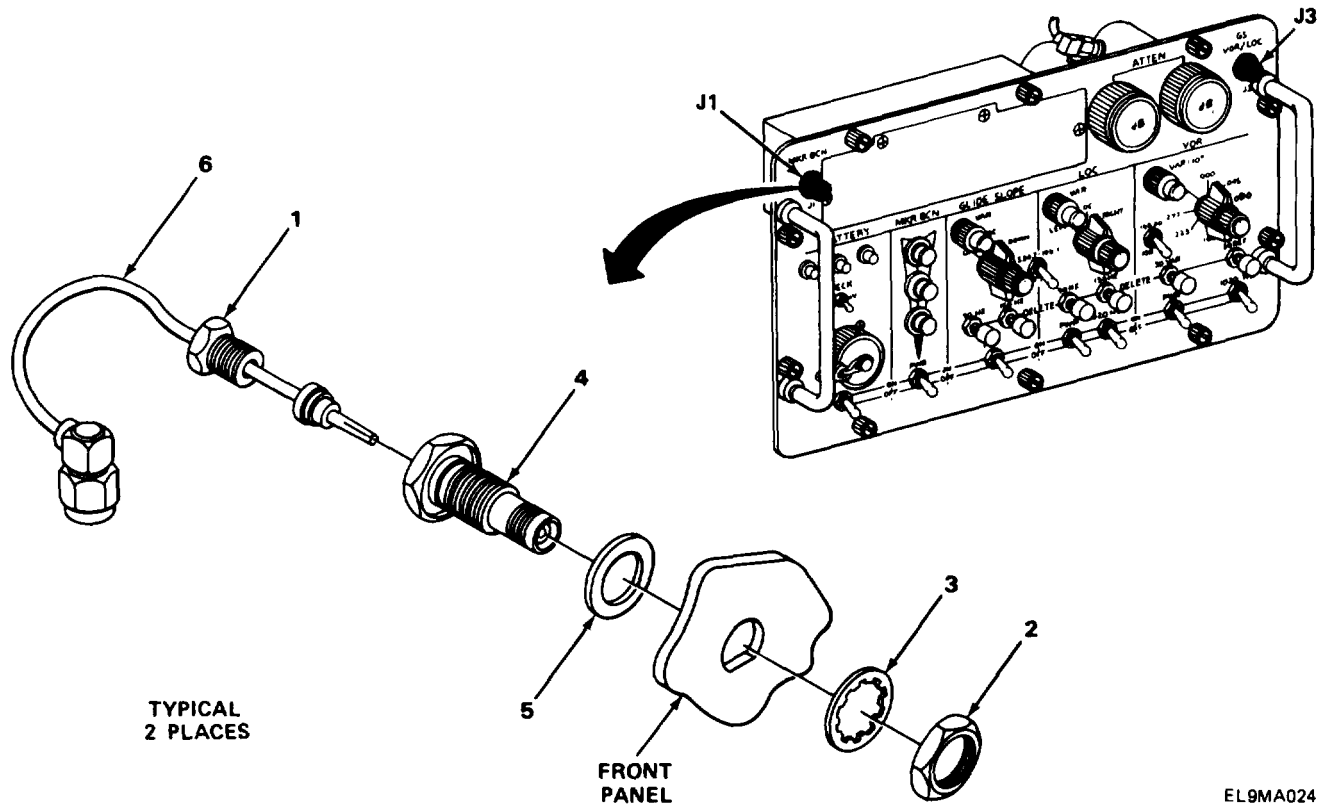

REMOVAL

NOTE

For removal of jack J1, battery case must first be removed (para 2-23).

Steps given are typical for both J1 and J3 antenna jacks.

1. Using wrench, remove wire retaining nut (1), jack retaining nut (2), and lockwasher(3).
2. Remove jack (4) and O-ring (5).

INSTALLATION

1. Position jack (4) and O-ring (5) in front panel, and install lockwasher (3) and jack retaining nut (2). Using wrench, tighten jack retaining nut (2).
2. Install wire retaining nut (1) and, using wrench, tighten.
3. For jack J1, install battery case (para 2-23).

FOLLOW-ON MAINTENANCE: Install A6 and A8 assembly (para 2-19).

2-22. ATTENUATOR SWITCH AT1 AND AT2 REPLACEMENT.

MATERIALS/PARTS: Attenuator, variable, AT1(P/N 378-0821-010)
 Attenuator, variable, AT2 (P/N 8122S)

PRELIMINARY PROCEDURE: Remove A6 and A8 assembly (para 2-19).

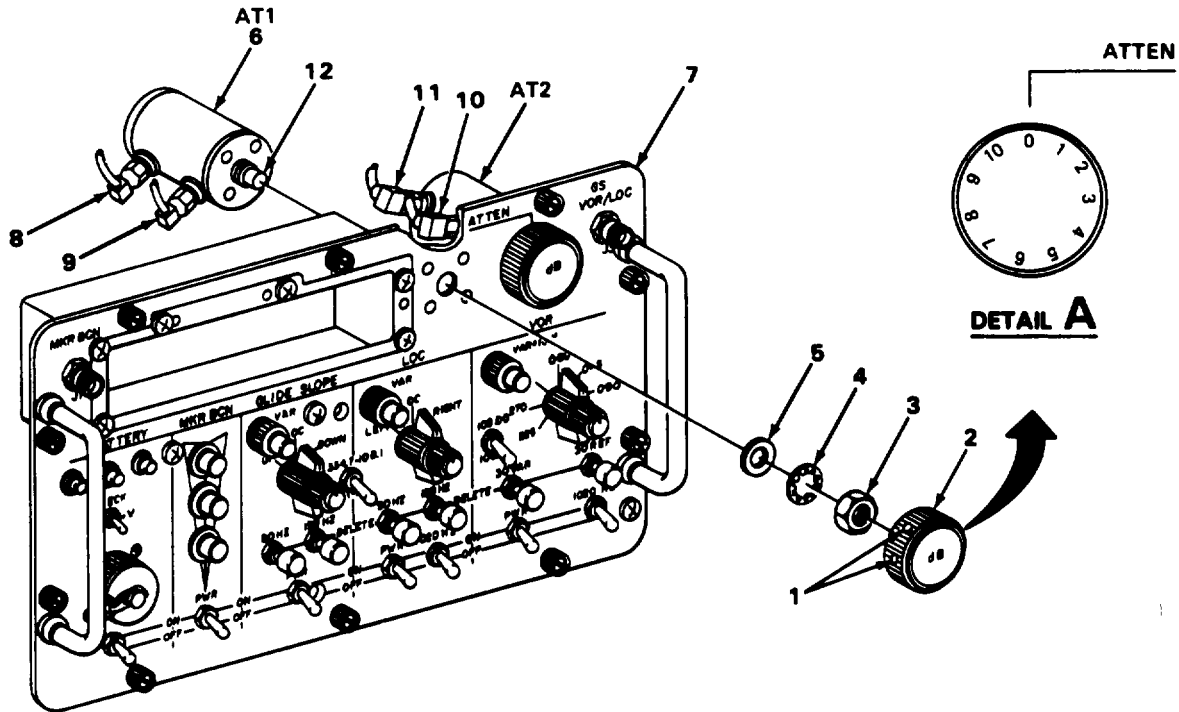

EL9MA021

REMOVAL

NOTE

Steps given are typical for both switches.

1. Using hex wrench, loosen two setscrews(1) and remove knob(2).
2. Using wrench, remove retaining nut (3), lockwasher (4), and fiat washer(5).
3. Push switch (6) out of front panel (7).

2-22. ATTENUATOR SWITCH AII AND AT2 REPLACEMENT. (CONT)**NOTE**

For AT1, do step 4.

For AT2, do step 5.

4. Disconnect RF cable connectors W8(8) and W7(9).
5. Disconnect RF cable connectors W7(10) and W9(11).
6. Remove switch (6).

INSTALLATION**NOTE**

For AT1, do step 1.

For AT2, do step 2.

1. Connect RF cable connectors W7(9) and W8(8).
2. Connect RF cable connectors W9(11) and W7(10).

NOTE

Steps given are typical for both switches.

3. Position switch (6) in front panel (7) and push into place.
4. Install flat washer(5), lockwasher (4), and nut (3).
5. Using wrench, tighten nut (3).
6. Install knob (2) on switch stem (12) and, using hex wrench, tighten two setscrews (1).

NOTE

For AT1 only, do steps 7, 8, and 9.

7. Turn knob (2) fully clockwise to stop.
8. Using hex wrench, loosen two setscrews(1) and rotate knob (2) to align 0 on knob with index mark on front panel as shown in detail A.
9. Using hex wrench, tighten two setscrews(1).

FOLLOW-ON MAINTENANCE: Install A6 and A8 assembly (para 2-19).
Anne attenuator control (para 2-15).

2-23. BATTERY CASE REPLACEMENT.

MATERIALS/PARTS: Case, battery (P/N 629-0728-001)
 Adhesive/sealer silicon (item 6, app B)
 PRELIMINARY PROCEDURE: Remove A6 and A8 assembly (para 2-19).

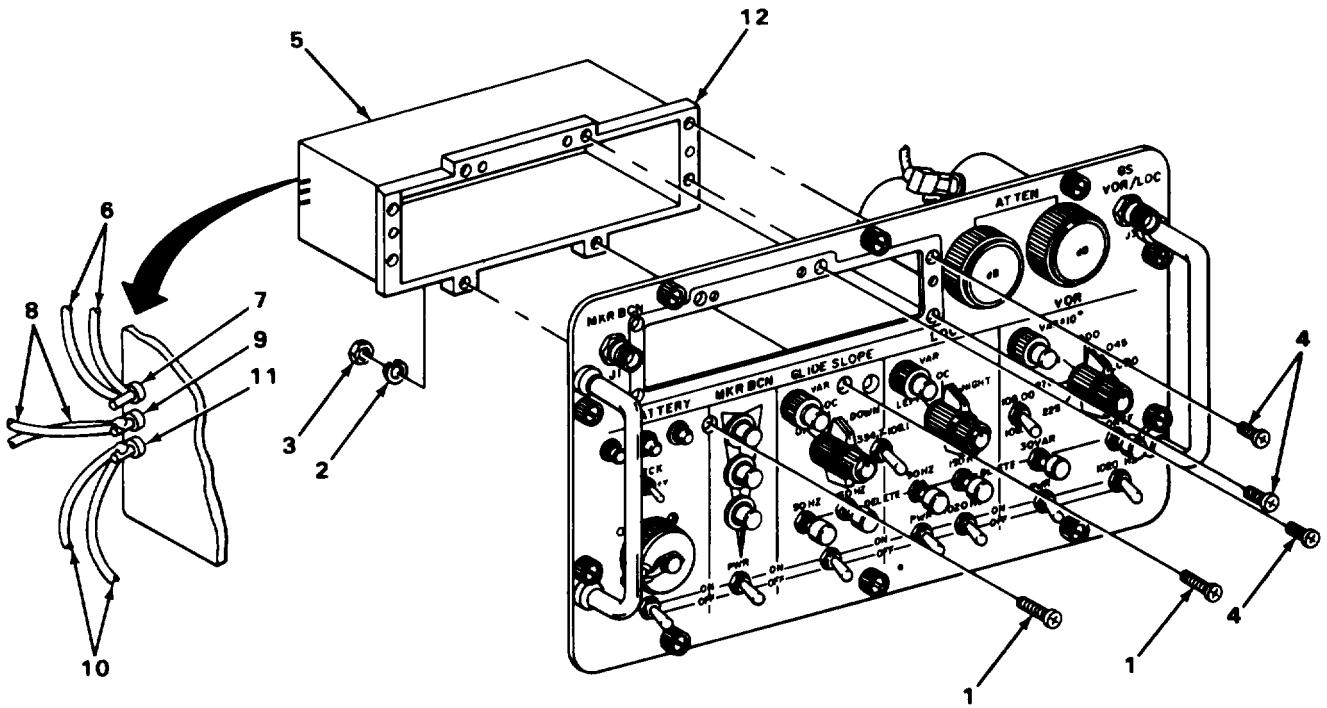

EL9MA022

REMOVAL

1. Using screwdriver and wrench, remove two screws (1), lockwashers (2), and nuts (3).
2. Using screwdriver, remove six screws (4) and move battery case (5) to side.
3. Using soldering iron, unsolder two orange wires (6) from top standoff (7), two black wires (8) from center standoff (9), and two red wires (10) from bottom standoff (11).
4. Remove battery case (5).

NOTE

If TB1 contact board is to be replaced, see paragraph 2-24.

2-23. BATTERY CASE REPLACEMENT. (CONT)

INSTALLATION

1. Using soldering iron, solder two red wires (10) to bottom standoff (11), two black wires (8) to center standoff (9), and two orange wires (6) to top standoff (7).
2. Apply a bead of sealant on lip (12) of battery case (5).

CAUTION

Care must be taken when performing next step to prevent pinching wires under battery case and front panel.

NOTE

See illustration for correct location of six screws (4).

3. Position battery case (5) on front panel and install six screws (4). Using screwdriver, tighten screws.
4. Install two screws (1), lockwashers (2), and nuts (3) and, using screwdriver and wrench, tighten.

FOLLOW-ON MAINTENANCE: Install A6 and A8 assembly (para 2-19).

2-24. TB1 CONTACT BOARD REPLACEMENT.

MATERIALS/PARTS: Contact board TB1 (P/N 629-0741-001)

PRELIMINARY PROCEDURE: Remove battery case (para 2-23).

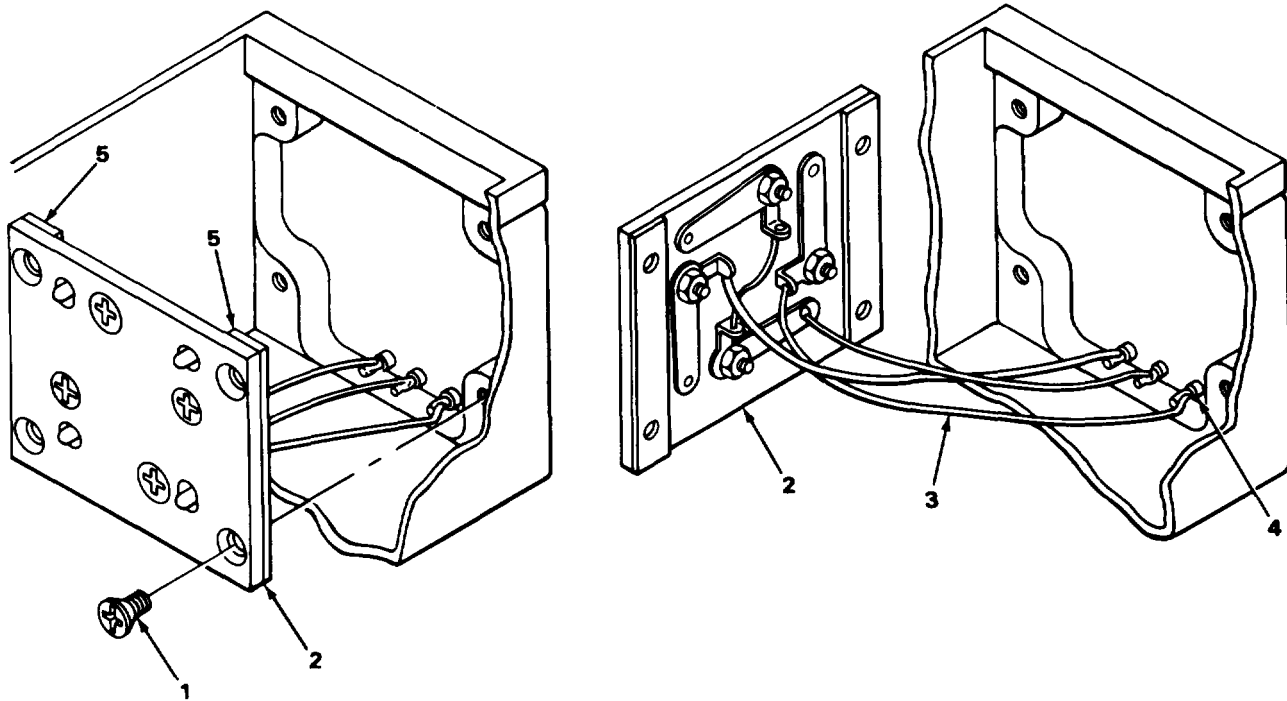

EL9MA023

REMOVAL

1. Using screwdriver, remove four screws (1) and free TB1 (2) from mounting.
2. Carefully turn TB1 (2) to gain access to wiring.
3. Using soldering iron, unsolder three wires (3) from three standoffs (4).
4. Remove TB1 (2) and two spacers (5).

INSTALLATION

1. Using soldering iron, solder three wires (3) to three standoffs (4) as shown.
2. Place TB1 (2) and two spacers (5) into position and install four screws (1). Using screwdriver, tighten screws.

FOLLOW-ON MAINTENANCE: Install battery case (para 2-23).

2-25. Pushbutton SWITCH S8, S9, S13, S14, S19, AND S20 REPLACEMENT.

MATERIALS/PARTS: Switch, push (P/N 46-1506)

PRELIMINARY PROCEDURE: Remove A6 and A8 assembly (para 2-19).

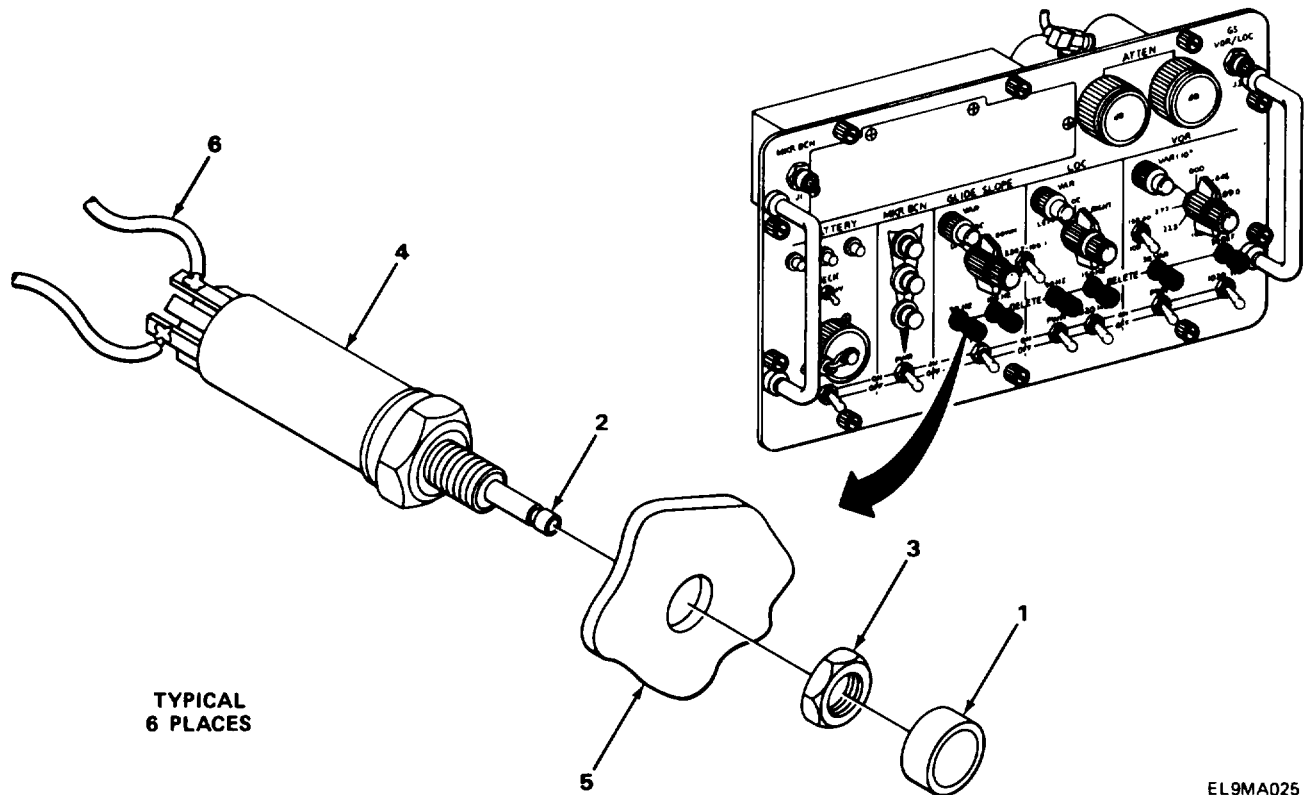

EL9MA025

REMOVAL

1. Remove switch cap (1) by pulling straight off switch stem (2).
2. Using two wrenches, remove retaining nut (3).
3. Push switch (4) out of front panel (5).
4. Using soldering iron, unsolder wires (6) one at a time and resolder to replacement switch.

INSTALLATION

1. Push switch (4) into front panel (5) and install retaining nut (3).
2. Using two wrenches, tighten retaining nut (3). Do not overtighten.
3. Push switch cap(1) onto switch stem (2).

FOLLOW-ON MAINTENANCE: Install A6 and A8 assembly (para 2-19).

2-26. TOGGLE SWITCH S1, S2, S8, S10, S12, S15, S16, S18, S21, AND S22 REPLACEMENT.

MATERIALS/PARTS: Switch, toggle(P/N 7201 SYZQE for S6, S16, and S18)

Switch, toggle (P/N 7401SYZE for S2, S10, S12, S15, S21, and S22)

Switch, toggle (P/N 7405SYZGE for S1)

PRELIMINARY PROCEDURE: Remove A6 and A8 assembly (para 2-19).

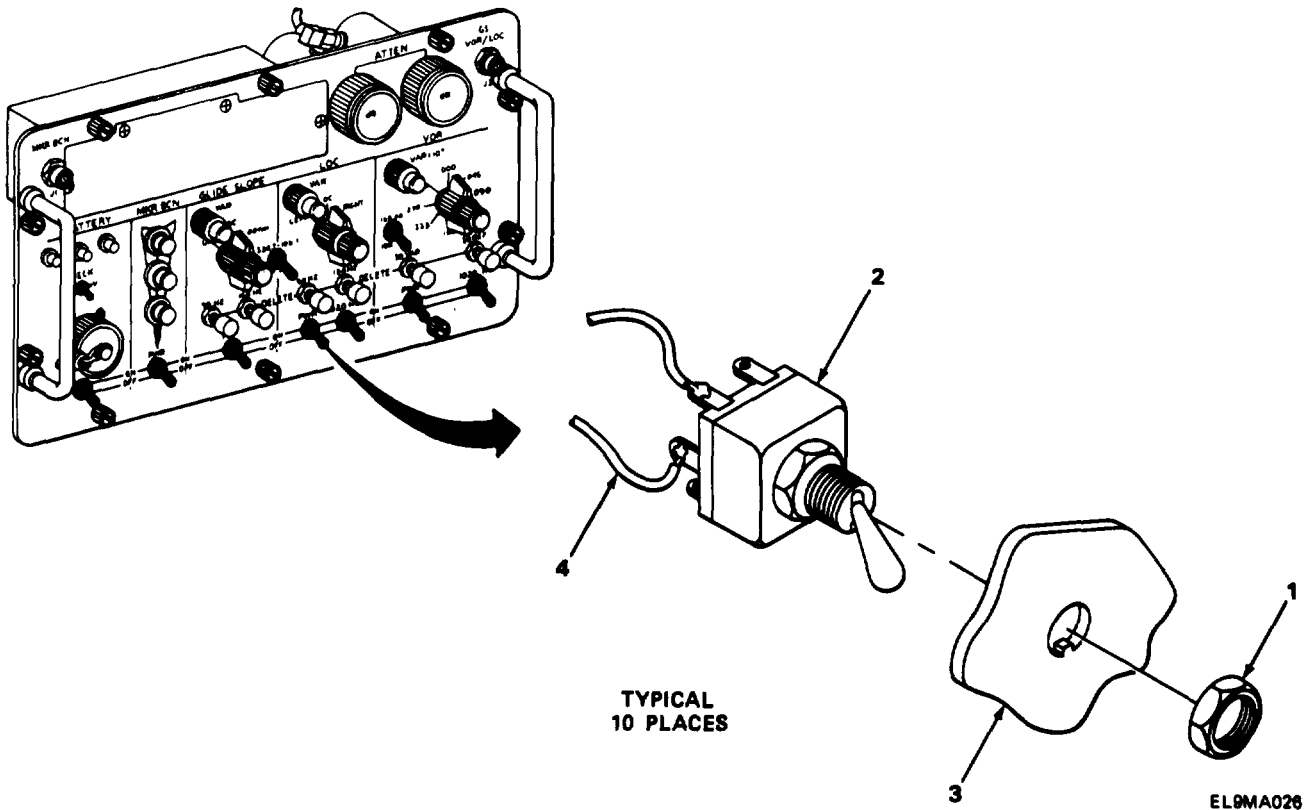

REMOVAL

1. Using wrench, remove retaining nut (1).
2. Push switch (2) out of front panel (3).
3. Using soldering iron, unsolder wires (4) one at a time and resolder to replacement switch.

INSTALLATION

1. Push switch (2) into front panel and install retaining nut (1).
2. Using wrench, tighten nut (1). Do not overtighten.

FOLLOW-ON MAINTENANCE: Install A6 and A8 assembly(para 2-19).

2-27. PUSHBUTTON SWITCH S23, S24, AND S25 REPLACEMENT

MATERIALS/PARTS: Switch, push (P/N 616-8-1)

PRELIMINARY PROCEDURE: Remove A6 and A8 assembly (para 2-19).

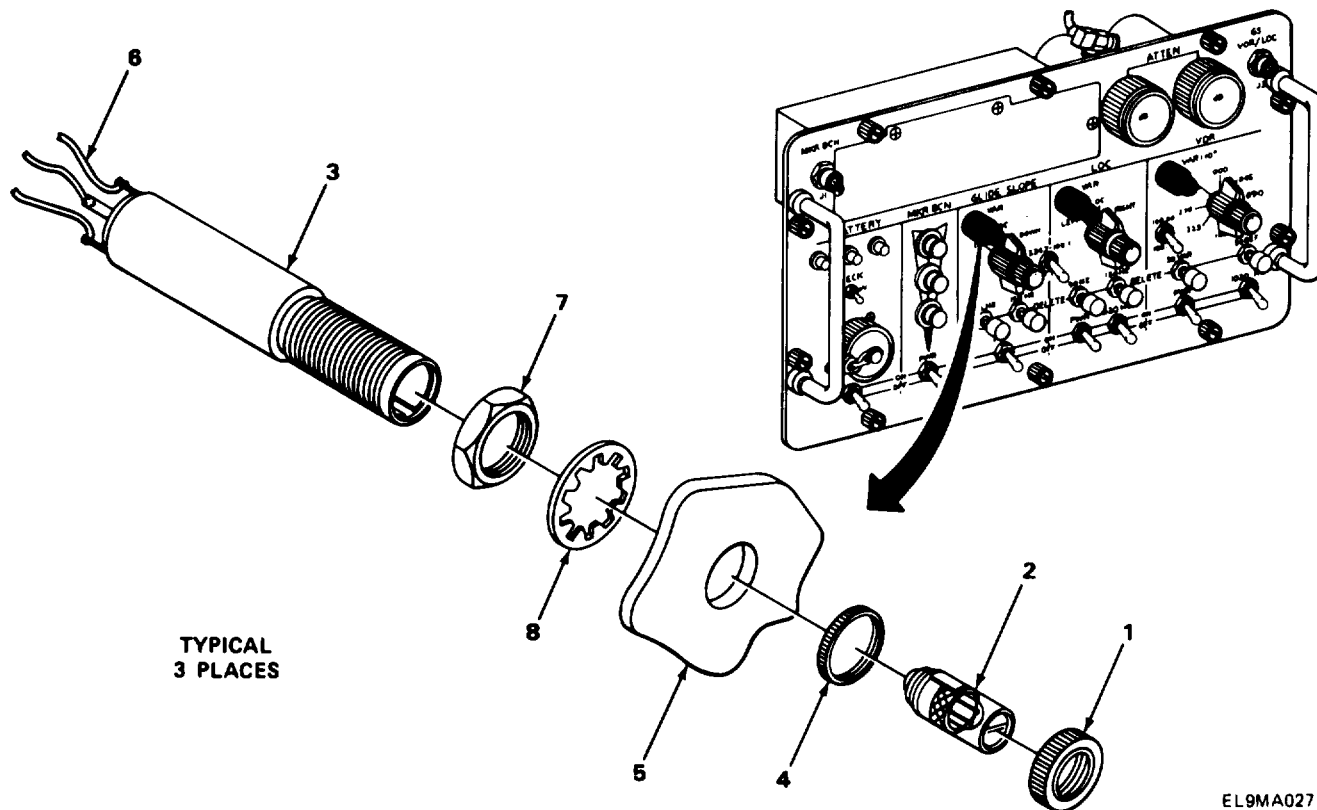
**REMOVAL**

1. Remove bulb retaining nut (1) and pull bulb (2) from switch (3).
2. Using pliers, carefully remove switch retaining nut (4) and push switch (3) out of front panel (5).
3. Using soldering iron, unsolder wires (6) one at a time and resolder to replacement switch.

INSTALLATION

1. Push switch (3) into front panel (5) and adjust nut (7) and lockwasher (8) to allow 1/4 inch of switch to protrude from front panel.
2. Install switch retaining nut (4) and, using pliers, tighten.
3. Install bulb (2) and bulb retaining nut (1). Hand tighten.

FOLLOW-ON MAINTENANCE: Install A6 and A8 assembly (para 2-19).

2-28. CONNECTOR J2 REPLACEMENT.

MATERIALS/PARTS: Connector, electrical (P/N MS3102R16-10P)

PRELIMINARY PROCEDURE: Remove A6 and A8 assembly (para 2-19).

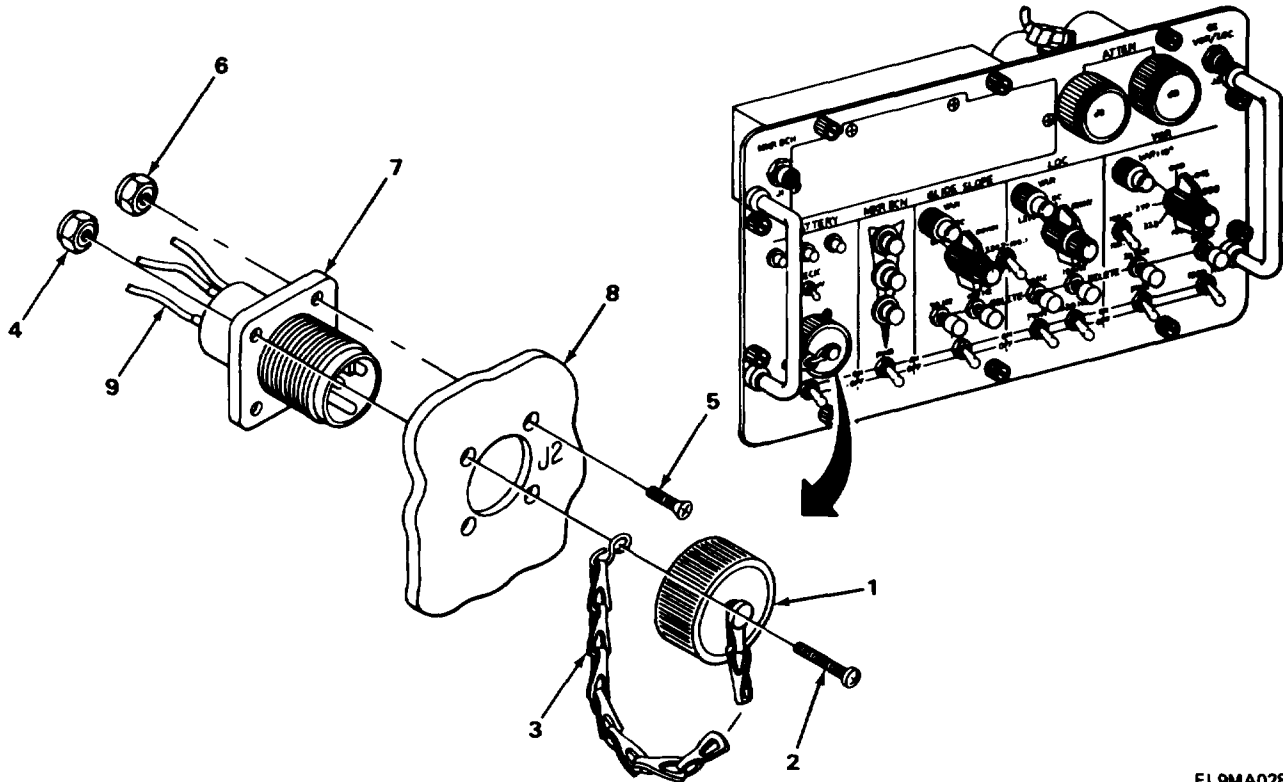

EL9MA028

REMOVAL

1. Remove protective cap (1).
2. Using screwdriver and wrench, remove long screw (2), chain (3), and nut (4).
3. Using screwdriver and wrench, remove three short screws (5) and nuts (6).
4. Push connector (7) out of front panel (8).
5. Using soldering iron, unsolder three wires (9) one at a time and resolder to replacement connector.

INSTALLATION

1. Push connector (7) into front panel (8) and install three short screws (5) and nuts (6).
2. Install chain (3), long screw (2), and nut (4).
3. Using screwdriver and wrench, tighten screws (5) and (2) and nuts (4) and (6).
4. Install protective cap (1).

FOLLOW-ON MAINTENANCE: Install A6 and A8 assembly (para 2-19).

2-29. INDICATOR LIGHT DS1, DS2, AND DS3 REPLACEMENT.

MATERIALS/PARTS: Light, indicator (P/N 102SR1H23H1)

PRELIMINARY PROCEDURE Remove A6 and A8 assembly (para 2-19).

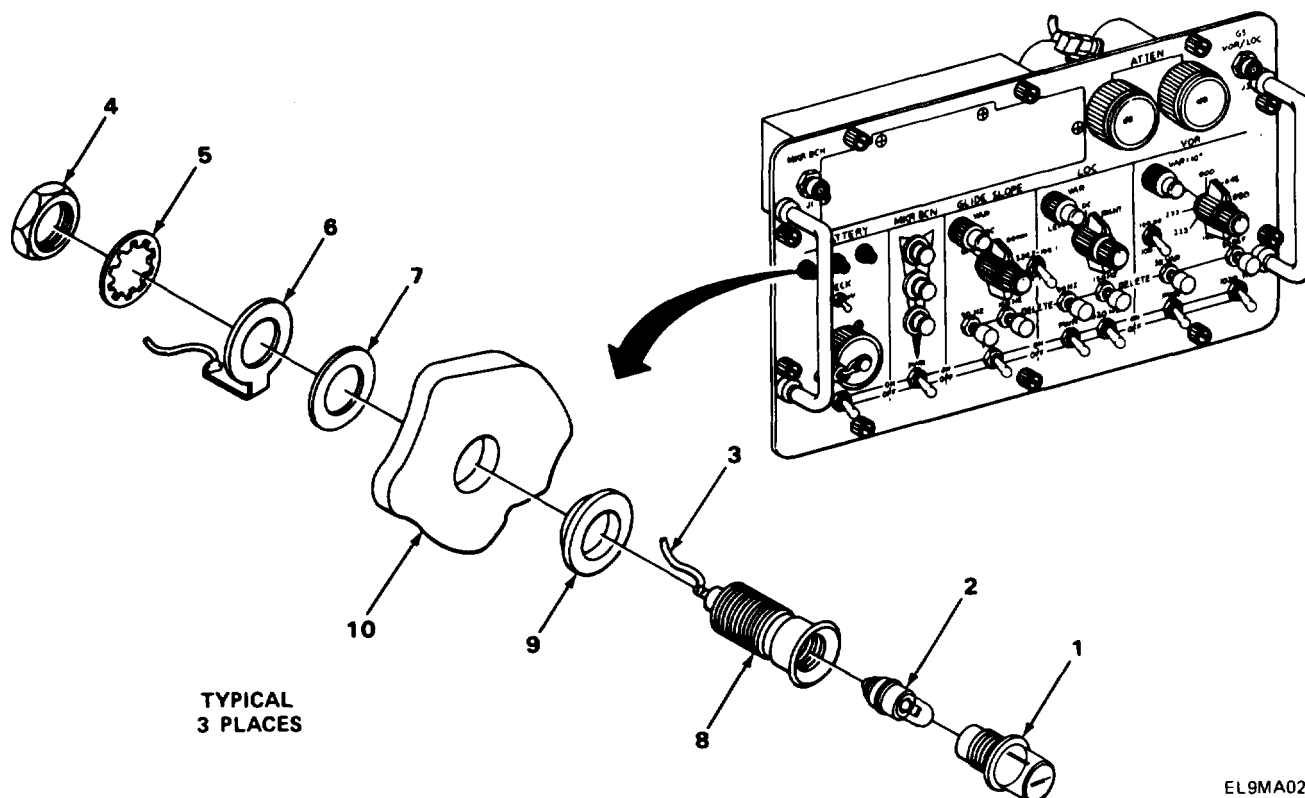
**REMOVAL**

1. Remove indicator lens (1) and bulb (2).
2. Using soldering iron, unsolder wire(s) (3).
3. Using wrench, remove nut (4), lockwasher (5), ground tab (6), and washer (7).
4. Remove indicator (8) and rubber grommet (9) from front panel (10).

NOTE

Connected ground tab (6) will be reused.

INSTALLATION

1. Push indicator (8) and rubber grommet (9) into front panel (10) and washer (7). Install ground tab (6), lockwasher (5), and nut (4).
2. Using pliers, tighten nut (4).
3. Using soldering iron, solder wire(s) (3) to indicator (8).
4. Install bulb (2) and indicator lens (1).

FOLLOW-ON MAINTENANCE: Install A6 and A8 assembly (para 2-19).

2-30. Pushbutton SWITCH S3, S4, AND S5 REPLACEMENT.

MATERIALS/PARTS: Switch, push, S3 (P/N 46-05-05-502-050)

Switch, push, S4 (P/N 46-05-05-502-060)

Switch, push, S5 (P/N 46-05-05-502-010)

PRELIMINARY PROCEDURE: Remove A6 and A8 assembly (para 2-19).

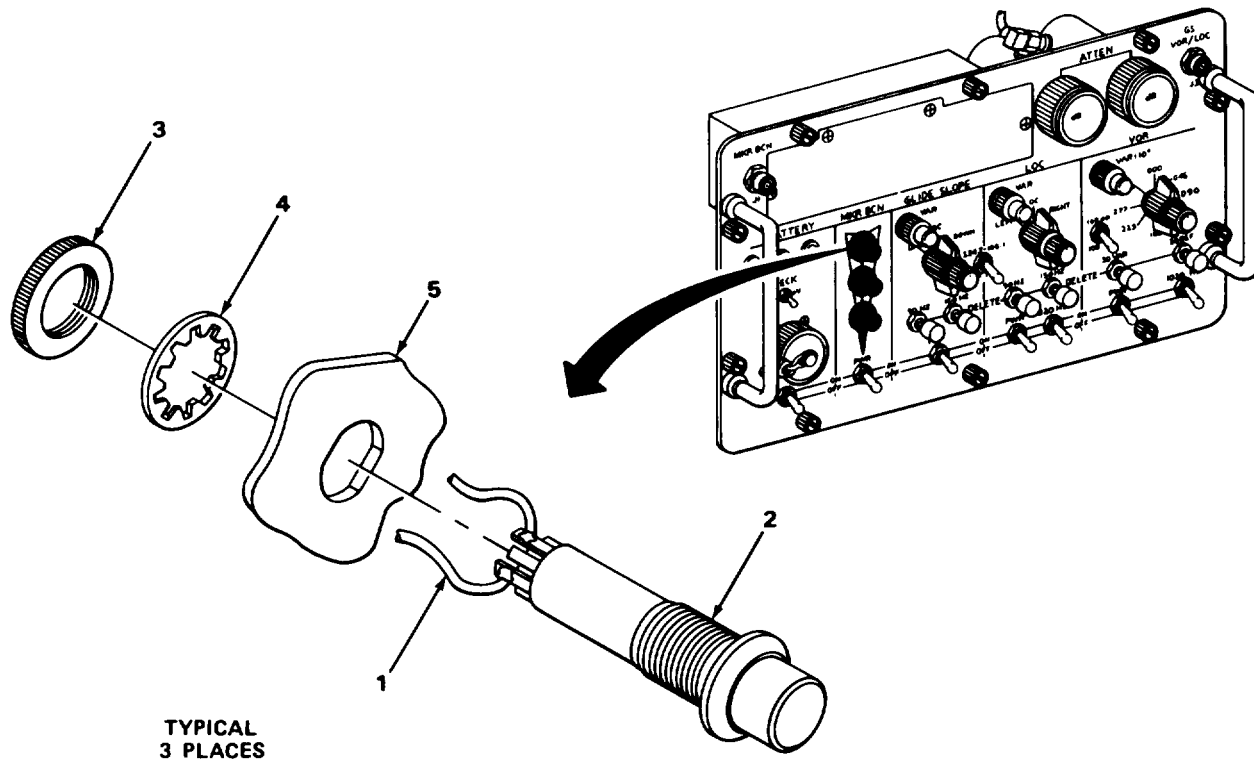

REMOVAL

1. Using soldering iron, unsolder three wires (1) from switch (2).
2. Using pliers, remove retaining nut (3) and lockwasher (4).
3. Remove switch (2) from front panel (5).

INSTALLATION

1. Push switch (2) into front panel (5) and install lockwasher (4) and retaining nut (3).
2. Using pliers, tighten retaining nut (3).
3. Using soldering iron, solder three wires (1) to switch (2).

FOLLOW-ON MAINTENANCE: Install A6 and A8 assembly (para 2-19).

2-31. IMPEDANCE MATCHING NETWORK A7 REPLACEMENT.

MATERIALS/PARTS: Signal combiner assembly A7 (P/N 629-0700-001)

PRELIMINARY PROCEDURE: Remove A6 and A8 assembly (para 2-19).

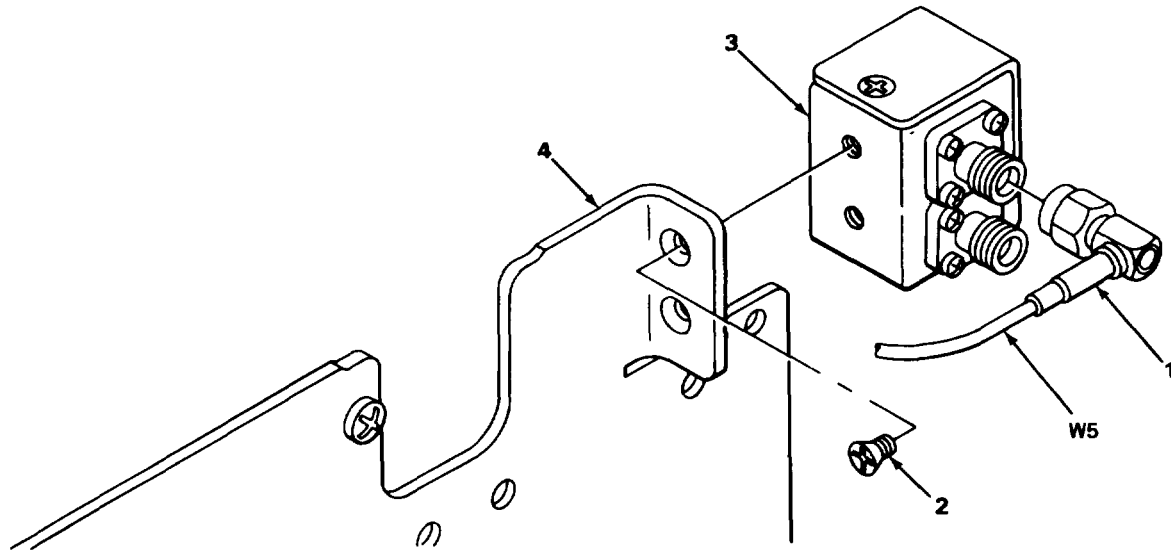
**REMOVAL**

1. Disconnect wire connector (1).
2. Using screwdriver, remove two screws (2) and A7 assembly (3).

INSTALLATION

1. Position A7 assembly (3) on bracket (4).
2. Install two screws (2).
3. Using screwdriver, tighten two screws (2).
4. Connect wire connector (1).

FOLLOW-ON MAINTENANCE Install A6 and A8 assembly (para 2-19).

2-32. ROTARY SWITCH S7, S11, AND S17 REPLACEMENT.

MATERIALS/PARTS: Switch, rotary for S7 and S11 (PIN SP6325)

Switch, rotary for S17 (P/N 259-8018-020)

PRELIMINARY PROCEDURE: Remove A6 and A8 assembly (para 2-19).

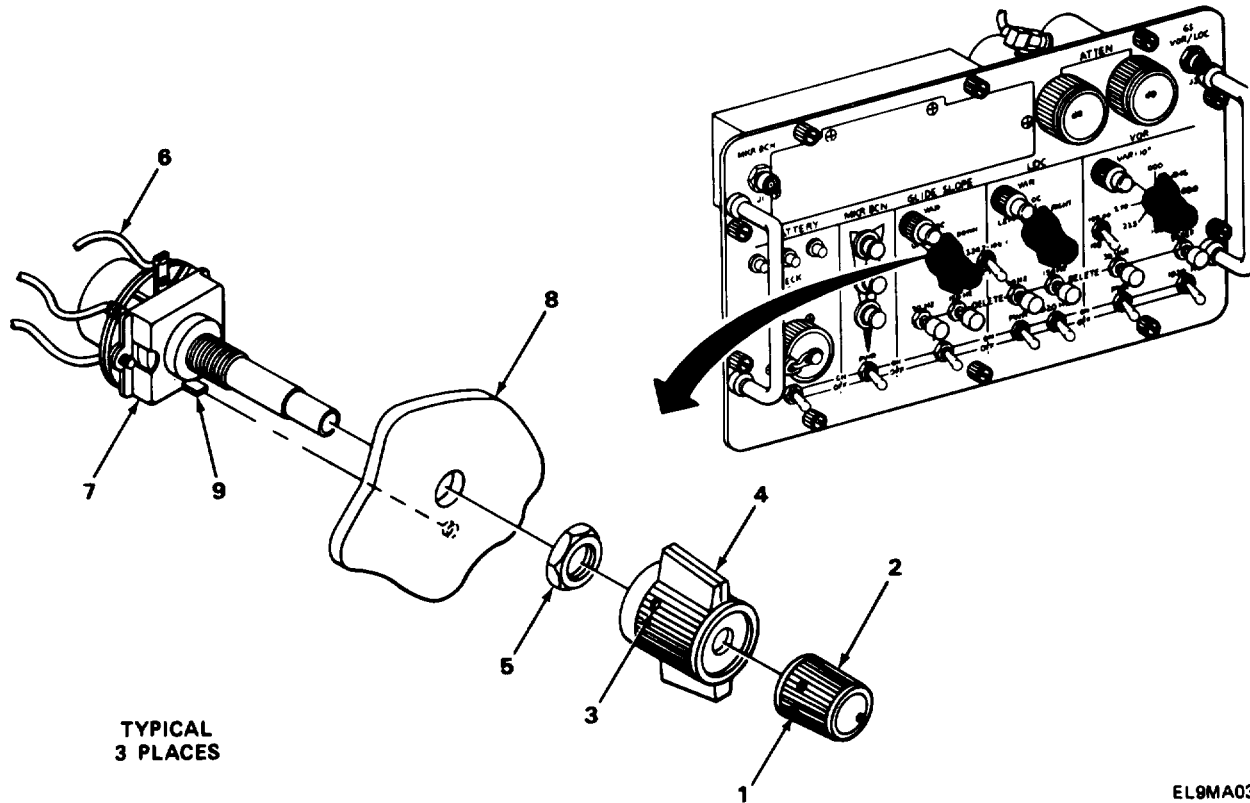

REMOVAL

1. Using hex wrench, loosen two setscrews (1) and remove knob (2).
2. Using hex wrench, loosen two setscrews (3) and remove knob (4).
3. Using wrench, remove retaining nut (5).
4. Using soldering iron, unsolder wires (6) one at a time and resolder to replacement switch.

INSTALLATION

1. Push switch (7) into front panel (8), placing locating pin (9) in hole in rear of front panel.
2. Install retaining nut (5).
3. Using wrench, tighten retaining nut (5).
4. Install knob (4) and, using hex wrench, tighten two setscrews (3).
5. Install knob (2) and, using hex wrench, tighten two setscrews (1).

2.32. ROTARY SWITCH S7, S11, AND S17 REPLACEMENT. (CONT)**NOTE**

For switches S7 and S11, do steps 6 through 11.

For switch S17, do steps 12 through 16.

6. Turn knob (4) fully counterclockwise to stop.
7. Loosen two setscrews (3) and turn knob (4) to align mark on knob with UP for switch S7 or LEFT for switch S11 on front panel.
8. Tighten two setscrews (3).
9. Turn knob (2) fully counterclockwise to stop.
10. Loosen two setscrews (1) and turn knob (2) to align dot on knob with OC on front panel.
11. Tighten two setscrews (1).
12. Turn knob (4) to any detent.
13. Loosen two setscrews (3) and turn knob (4) to align mark on knob with any degree mark on front panel.
14. Tighten two setscrews (3).
15. Turn knob (2) fully counterclockwise to stop.
16. Loosen two setscrews (1) and turn knob (2) to align dot on knob with 000 on front panel.

FOLLOW-ON MAINTENANCE: Install A6 and A8 assembly (para 2.19).

2-33. FRONT PANEL REPLACEMENT.

MATERIALS/PARTS: Panel, front, assembly (P/N 629-0197-002)

PRELIMINARY PROCEDURE: Remove electronic components assembly (para 2-17).

NOTE

Front panel replacement involves removal and installation of components attached to panel. Paragraphs are listed in order in which procedures are to be performed. When completed, front panel is ready for replacement.

REMOVAL

1. Remove A6 and A8 assembly (para 2-19).
2. Remove antenna jack J1 and J3 (para 2-21).
3. Remove attenuator switch AT1 and AT2 (para 2.22).
4. Remove battery case (para 2-23).
5. Remove pushbutton switch S8, S9, S13, S14, S19, and S20 (para 2-25).
6. Remove toggle switch S1, S2, S6, S10, S12, S15, S16, S18, S21, and S22 (para 2-26).
7. Remove pushbutton switch S23, S24, and S25 (para 2-27).
8. Remove connector J2 (para 2-28).
9. Remove Indicator light DS1, DS2, and DS3 (para 2-29).
10. Remove pushbutton switch S3, S4, and S5 (para 2-30).
11. Remove rotary switch S7, S11, and S17 (para 2-32).
12. Remove two screws from each handle and remove both handles.

2-33. FRONT PANEL REPLACEMENT. (CONT)

INSTALLATION

1. Install two handles and secure with two screws each.
2. Install rotary switch S7, S11, and S17 (para 2-32).
3. Install pushbutton switch S3, S4, and S5 (para 2-30).
4. Install Indicator light DS1, DS2, and DS3 (para 2-29).
5. Install connector J2 (para 2-28).
6. Install pushbutton switch S23, S24, and S25 (para 2-27).
7. Install toggle switch S1, S2, S6, S10, S12, S15, S16, S18, S21, and S22 (para 2-26).
8. Install pushbutton switch S8,S9,S13, S14, S19, and S20 (para 2-25).
9. Install battery case (para 2-23).
10. Install attenuator switch AT1 and AT2 (para 2-22).
11. Install antenna jack J1 and J3 (para 2-21).
12. Install A6 and A8 assembly (para 2-19).

FOLLOW-ON MAINTENANCE: Install electronic components assembly (para 2-17).

2-34. BATTERY CHARGER CONVERSION TO 230 VAC OPERATION.

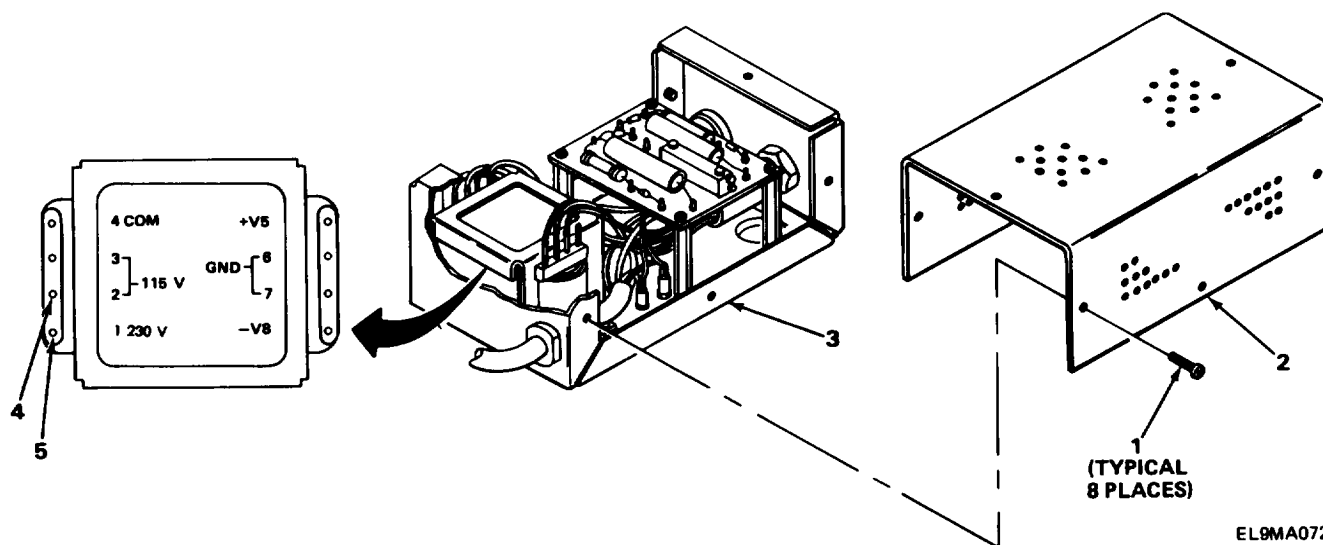

1. Remove eight screws (1) from battery charger cover (2).
2. Remove battery charger cover (2) from battery charger (3).
3. Unsolder wire from transformer (115 v) input 2 (4) and solder to transformer (230 v) input 1 (5).
4. Position battery charger cover (2) on battery charger (3) and secure with eight screws (1).

2.35. PAINTING.

Refer to TB 43-0118 for painting and touch up instructions.

2-36. PLACING IN SERVICE.

Before returning the test set to service, perform the calibration procedures in TB 9-6625-2052-35.

2-37. BATTERY CHARGER COVER REPLACEMENT.

MATERIALS/PARTS: Cover, battery charger (P/N 629-0131-001)

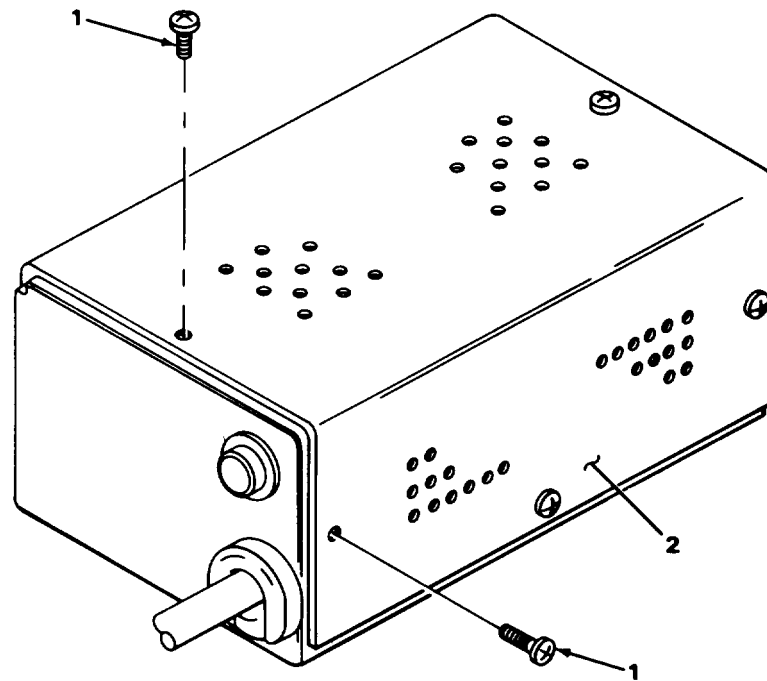

EL9MA082

REMOVAL

1. Remove eight screws (1) from top and sides of cover (2).
2. Lift cover (2) off chassis.

INSTALLATION

1. Position cover (2) on chassis and align screw holes.
2. Install eight screws (1) through top and sides of cover (2).

2-38. BATTERY CHARGER TRANSFORMER T1 REPLACEMENT.

MATERIALS/PARTS: Transformer assembly T1(P/N 629-9110-001)

PRELIMINARY PROCEDURE: Remove battery charger cover (para 2-37).

| WIRE COLOR | INDEX NO. | NOTES |
|------------|-----------|-------|
| YEL | 1 | |
| GRN | 2 | |
| JUMPER | 3 | |
| BRN | 4 | |
| WHT | 5 | |
| BLK | 6 | A |
| JUMPER | 7 | |
| BLK | 8 | B |

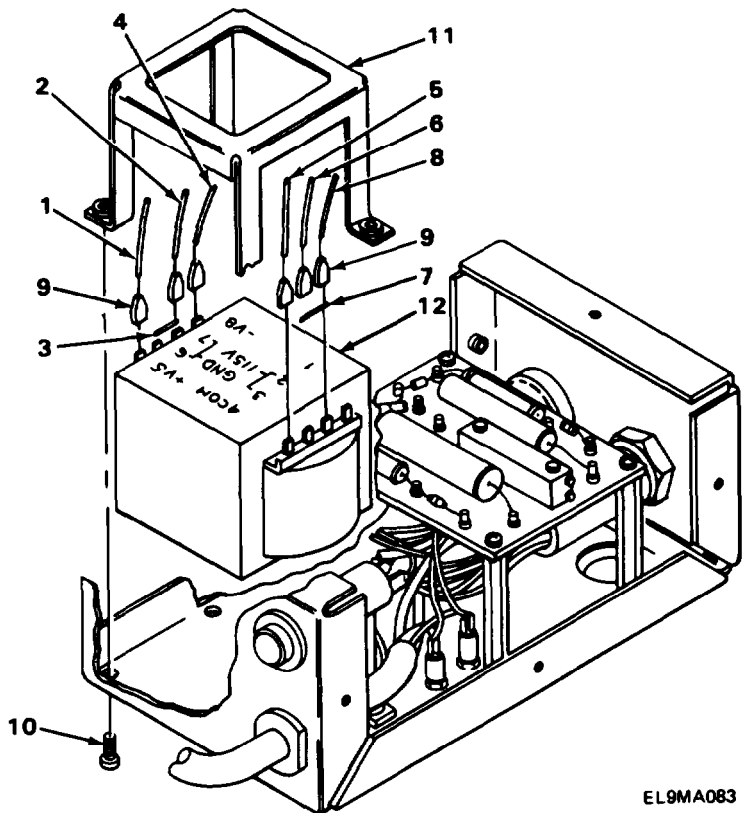

NOTES:
 A. WIRE IS FROM INDICATOR LAMP
 B. WIRE IS FROM FUSE HOLDER

EL9MA083

REMOVAL

1. Unsolder wires from transformer as shown in table above.
2. Remove heat shrink tubing (9) from all wires and unsolder wires as shown in table above.
3. Remove four screws (10) and lift transformer bracket(11) and transformer (12) from chassis.

INSTALLATION

NOTE

Position information plate on transformer as shown.

1. Install transformer (12) and transformer bracket(11) in chassis.
2. Install four screws (10) from bottom of chassis.
3. Install heat shrink tubing (9) on all wires. Do not shrink at this time.
4. Solder wires as shown in table above.
5. Slide heat shrink tubing (9) over solder points and shrink to fit.

FOLLOW-ON MAINTENANCE: Install battery charger cover (para 2-37).

2-39. BATTERY CHARGER CIRCUIT CARD AI REPLACEMENT.

MATERIALS/PARTS: Electronic components assembly A1 (P/N 629-0133-001)

PRELIMINARY PROCEDURE: Remove battery charger cover (para 2-37).

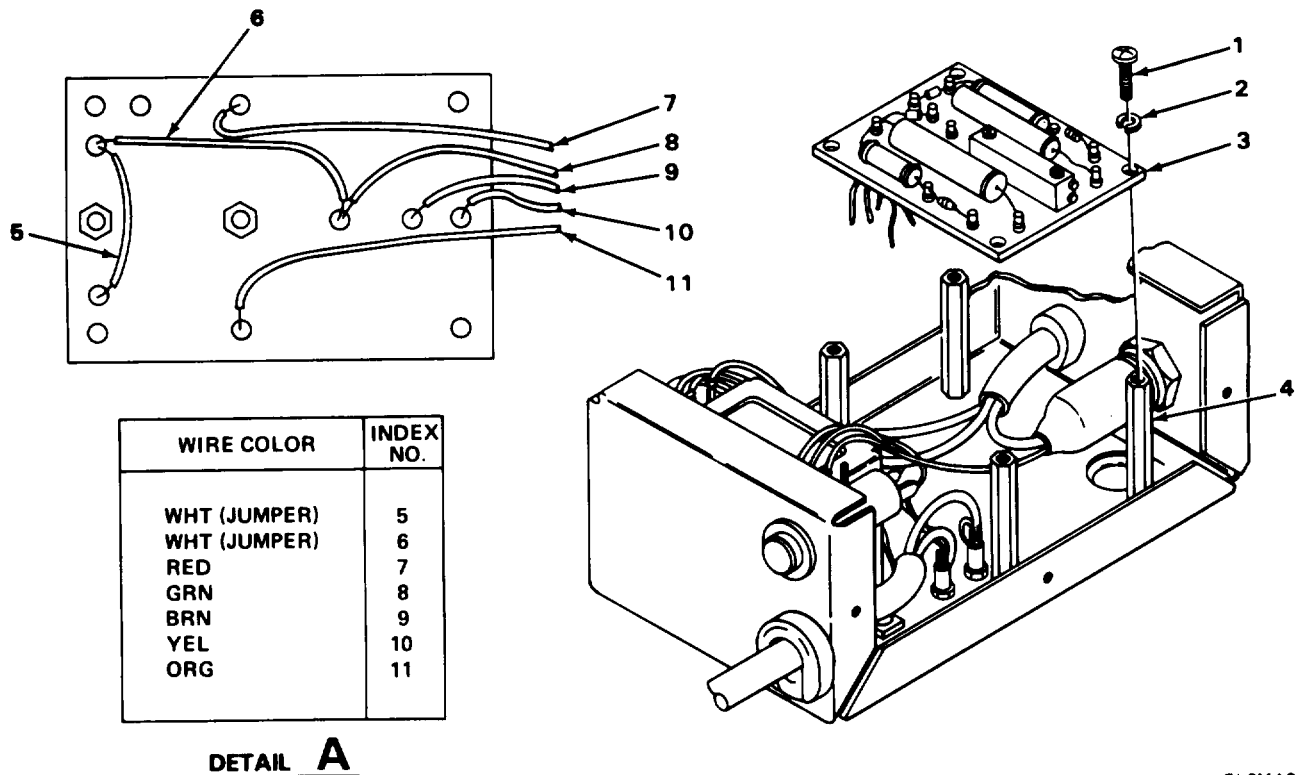

EL9MA084

REMOVAL

1. Remove four screws (1) and lockwashers (2) and lift circuit card (3) off standoffs (4).
2. Unsolder wires from rear of circuit card (3) as shown in detail A.
3. Remove circuit card (3).

INSTALLATION

1. Solder wires to rear of circuit card (3) as shown in detail A.
2. Position circuit card (3) on standoffs (4) and install four screws (1) and lockwashers (2).

FOLLOW-ON MAINTENANCE: Install battery charger cover (para 2-37).

2-40. BATTERY CHARGER INDICATOR LIGHT DS1 REPLACEMENT.

MATERIALS/PARTS: Light, indicator DS1(P/N 32R2115T)

PRELIMINARY PROCEDURE: Remove battery charger cover (para 2-37).

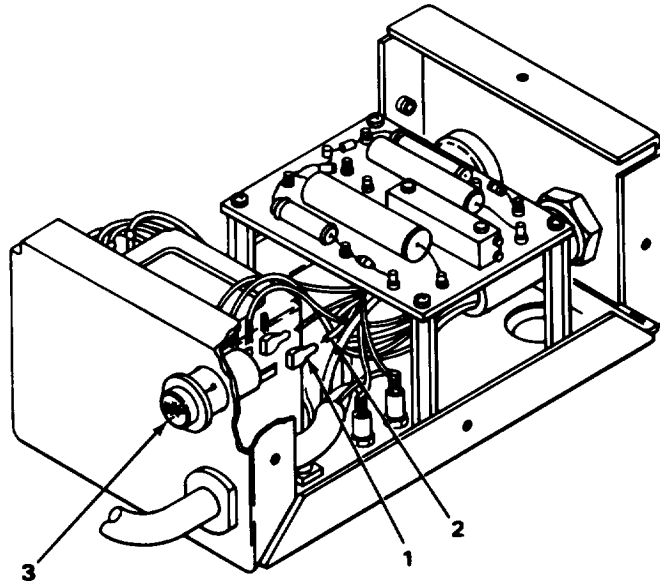

EL9MA085

REMOVAL

1. Remove heat shrink tubing (1) from two wires.
2. Unsolder two wires (2) from indicator light (3).
3. Push indicator light (3) out of chassis.

INSTALLATION

1. Push indicator light (3) into chassis.
2. Install heat shrink tubing (1) on two wires (2). Do not shrink at this time.
3. Solder two wires (2) to indicator light (3).
4. Slide heat shrink tubing (1) over solder points and shrink to fit.

FOLLOW-ON MAINTENANCE Install battery charger cover (para 2-37).

2-41. BATTERY CHARGER POWER CABLE REPLACEMENT.

MATERIALS/PARTS: Cable assembly, power (P/N 062-6219752CP353)

PRELIMINARY PROCEDURE: Remove battery charger cover (para 2-37).

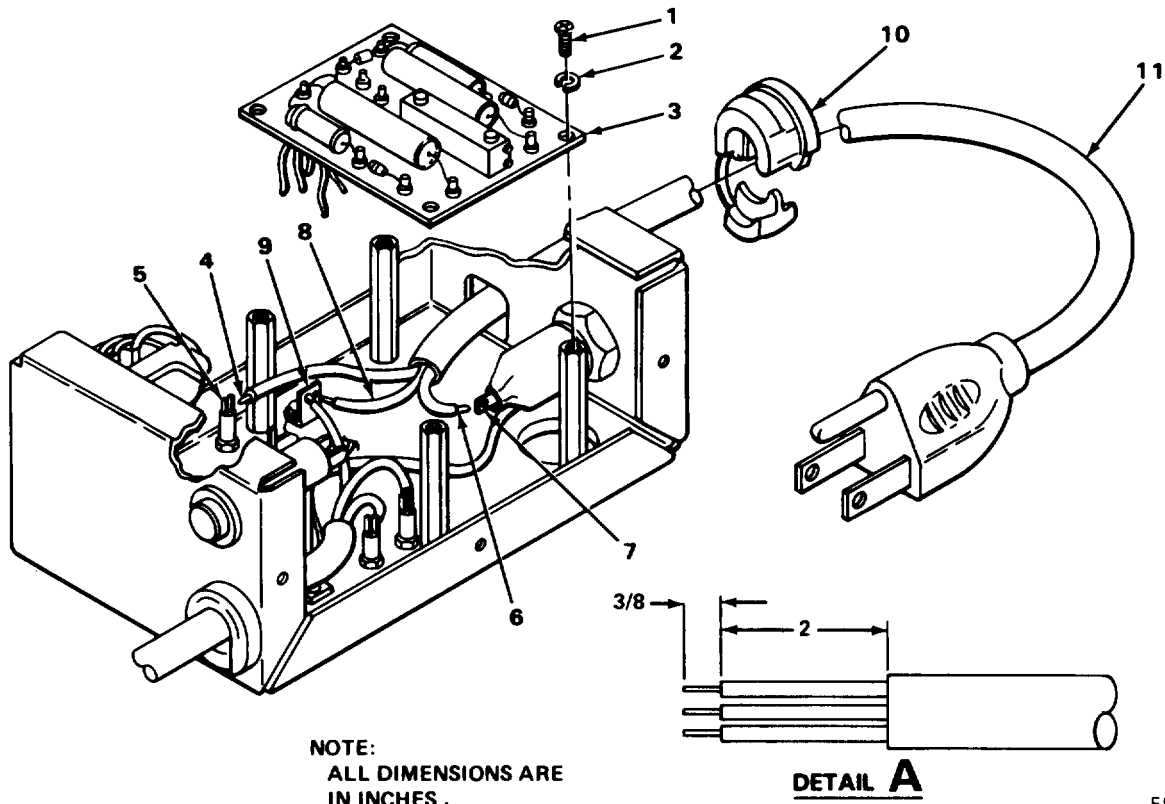

EL9MA086

REMOVAL

1. Remove four screws (1), lockwashers (2), and move circuit board A1 (3) to side.
2. Unsolder tan wire (4) from standoff (5), black wire (6) from fuse holder (7), and green wire (8) from ground lug (9).
3. Push strain relief bushing (10) off cable (11) from inside of chassis.
4. Remove cable (11).

INSTALLATION

1. Prepare cable as shown in detail A.
2. Push prepared end of cable (11) into chassis.
3. Solder green wire (8) to ground lug (9), black wire (6) to fuse holder (7), and tan wire (4) to standoff (5).
4. Position strain relief bushing (10) on cable (11) near chassis wall and push into place.
5. Position circuit board A1 (3) on standoffs and install four screws (1) and lockwashers (2).

FOLLOW-ON MAINTENANCE: Install battery charger cover (para 2-37).

2-42. BATTERY CHARGER LOW VOLTAGE SUPPLY CABLE REPLACEMENT.

MATERIALS/PARTS: Cable, roll, cut to 39 inches (P/N E-11651-W)
 Connector, plug, electrical, If needed (P/N CA3106E16-10S)

PRELIMINARY PROCEDURE: Remove battery charger cover (para 2-37).

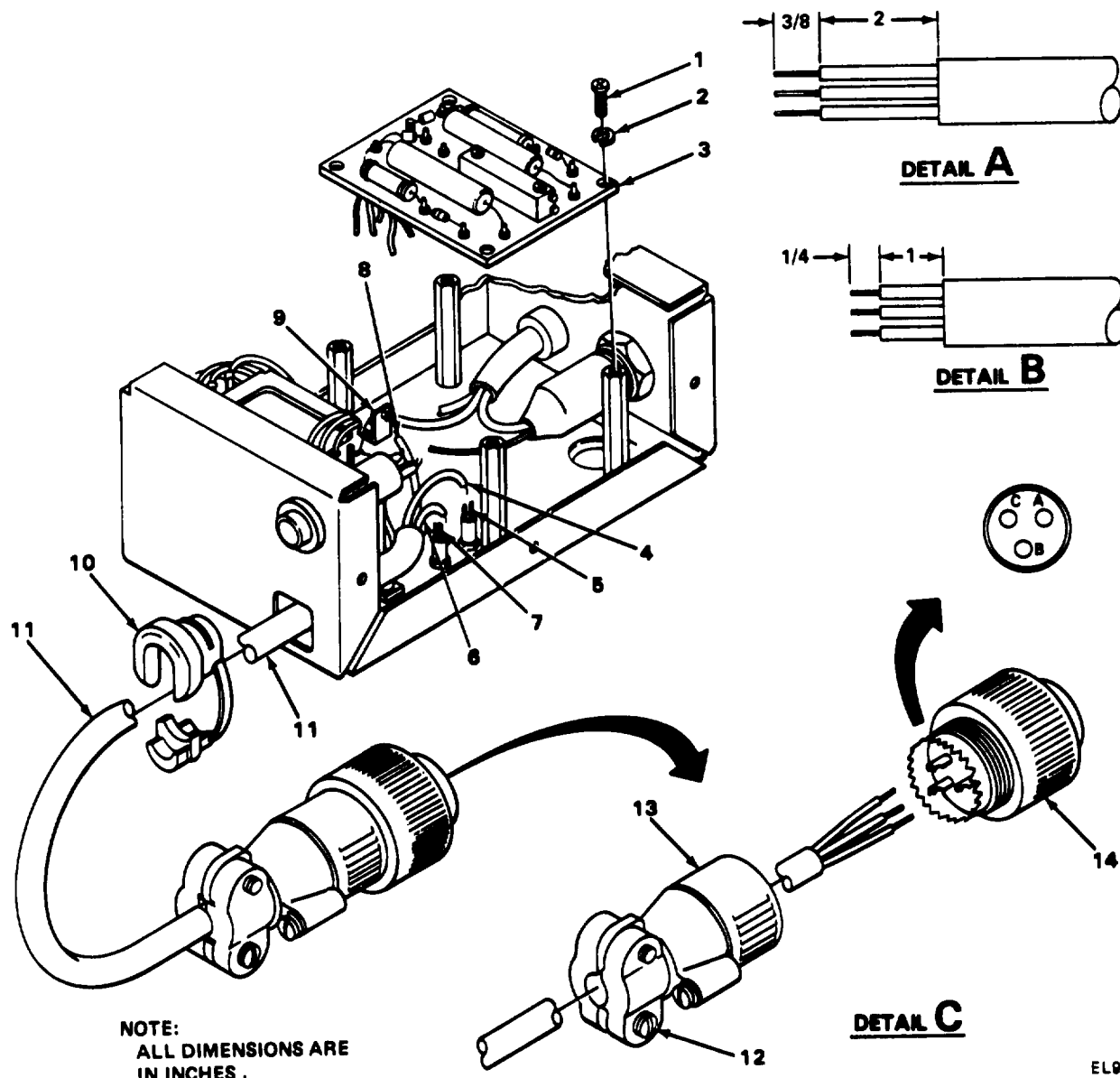

NOTE:
 ALL DIMENSIONS ARE
 IN INCHES .

ELQMA087

2-42. BATTERYCHARGER LOW VOLTAGE SUPPLY CABLE REPLACEMENT. (CONT)**REMOVAL**

1. Remove four screws (1), lockwashers (2), and move circuit board A1 (3) to side.
2. Unsolder tan wire (4) from standoff (5), black wire (6) from standoff (7), and green wire (8) from ground lug (9).
3. Push strain relief bushing (10) off cable(11) from inside of chassis.
4. Remove cable (11).
5. Loosen two screws (12) on connector shell (13) and unscrew connector shell from electrical connector (14).
6. Unsolder black wire from terminal A, tan wire from terminal B, and green wire from terminal C on electrical connector (14) as shown in detail C.
7. Remove electrical connector (14).

INSTALLATION

1. Prepare one end of cable (11) as shown in detail A.
2. Push prepared end of cable (11) into chassis,
3. Solder green wire (8) to ground lug (9), black wire (6) to standoff (7), and tan wire (4) to standoff (5).
4. Position strain relief bushing (10) on cable (11) near chassis wall and push into place.
5. Position circuit board A1 (3) on standoffs and install four screws (1) and lockwashers (2).
6. Prepare remaining end of cable (11) as shown in detail B.
7. Push prepared end of cable(11) through connector shell (13) as shown in detail C.
8. Solder black wire (6) to terminal A, tan wire (4) to terminal B, and green wire (8) to terminal C on electrical connector (14).
9. Screw connector shell (13) to electrical connector (14).
10. Tighten two screws (12) on connector shell (13).

FOLLOW-ON MAINTENANCE: Install battery charger cover (para 2-37).

APPENDIX A

REFERENCES

A-1. SCOPE.

This appendix lists all pamphlets, forms, service catalogues, service bulletins, technical bulletins, and technical manuals referenced in this manual.

A-2. PAMPHLETS.

Consolidated Index of Army Publications and Blank Forms DA PAM 310-1
 The Army Maintenance Management System (TAMMS)..... DA PAM 738-750

A-3. FORMS.

Recommended Changes to Publications and Blank Forms..... DA FORM 2028
 Recommended Changes to Equipment Technical Manuals DA FORM 2028-2
 Equipment inspection and Maintenance Worksheet..... DA FORM 2404
 Discrepancy in Shipment Report (DISREP) SF 361
 Report of Discrepancy (ROD) SF 364
 Quality Deficiency Report SF 368

A-4. SERVICE CATALOGUES.

Calibration Kit TB 9-6625-2052-35

A-5. SERVICE BULLETINS.

Painting and Preservation Supplies Available for Field Use for
 Electronics Command Equipment..... SB 11-573
 Preservation, Packaging, Packing, and Marking Materials, Sup-
 plies, and Equipment Used by the Army..... SB 38-100

A-6. TECHNICAL BULLETINS.

Field instructions for Painting and Preserving Electronics
 Command Equipment including Camouflage Pattern Painting of
 Electrical Equipment Shelters TB 43-0118
 Calibration Procedure for Receiver Test Set AN/ARM-186 TB 9-6625-2052-35

A-7. TECHNICAL MANUALS.

Operator's and Organizational Maintenance Manual: Test Set,
 Receiver AN/ARM-186 (NSN 6625-00-557-1168) TM 11-6625-2976-12
 Organizational, Direct Support, and General Support Maintenance
 Repair Parts and Special Tools Lists for Test Set Receiver
 AN/ARM-186 (NSN 6625-00-557-1168) TM 11-6625-2976-24P
 Administrative Storage of Equipment..... TM 740-90-1
 Procedure for Destruction of Electronics Materiel to Prevent
 Enemy Use TM 750-244-2

APPENDIX B

EXPENDABLE SUPPLIES AND MATERIALS LIST

B-1. SCOPE

This appendix lists expendable supplies and materials you will need to maintain the Test Set, Receiver AN/ARM-186. These Items are authorized to you by CTA 50-970, Expendable Items (except Medical, Class V, Repair Parts, and Heraldic Items).

B-2. EXPLANATION OF COLUMNS.

a. Column (1), Item Number. This number is assigned to the entry in the listing and is referenced in the narrative instructions to identify the material (for example, "Use cleaning compound, item 6, appendix B").

b. Column (2), Level. This column identifies the lowest level of maintenance that requires the listed item.

H - General Support Maintenance

c. Column (3), National Stock Number. This is the National stock number assigned to the item; use it to request or requisition the item.

d. Column (4), Description. Indicates the Federal item name and, if required, a description to identify the item. The last line for each item indicates the Federal Supply Code for Manufacturer (FSCM) in parentheses followed by the part number.

e. Column (5), Unit of Measure (U/M). Indicates the measure used in performing the actual maintenance function. This measure is expressed by a two-character alphabetical abbreviation (e.g., ea, in., pr). If the unit of measure differs from the unit of issue, requisition the lowest unit of issue that will satisfy your requirements.

EXPENDABLE SUPPLIES AND MATERIALS LIST

| (1) ITEM NUMBER | (2) LEVEL | (3) NATIONAL STOCK NUMBER | (4) DESCRIPTION (FSCM) | (5) U/M |
|-----------------------|--------------|---------------------------------|---------------------------|----------------|
| 1 | H | 8040-00-843-0802 | ADHESIVE/SEALER SILICON | TUBE (3 OZ) |

GLOSSARY

Section I ABBREVIATIONS

| | |
|---------------|-----------------------------------|
| ATTEN | attenuator |
| DDM | difference in depth of modulation |
| GS | glide slope |
| LOC | localizer |
| MKR BCN or MB | marker beacon |
| OC | on course |
| PWR | power |
| VAR | variable |
| VHF | very high frequency |
| VOR | vhf omnidirectional range |

Section II DEFINITION OF UNUSUAL TERMS

Azimuth. Horizontal direction.

Omnidirectional Range. A radio aid to navigation which indicates the magnetic bearing (omnibearing) of that station from any azimuth.

INDEX

| Subject | Page |
|---|------------|
| A | |
| Abbreviations | Glossary 1 |
| Administrative storage | 1-2 |
| Alinement procedures | 2-39 |
| ATTEN control alinement | 2-57 |
| General | 2-39 |
| GS mode adjustment | 2-42 |
| LOC mode adjustment | 2-39 |
| MB mode adjustment..... | 2-50 |
| Operating voltage adjustment..... | 2-52 |
| VOR bearing selector control alinement..... | 2-55 |
| VOR mode adjustment | 2-45 |
| Antenna jack J1 and J3 replacement..... | 2-65 |
| A6 and A8 assembly replacement..... | 2-62 |
| A6 circuit board assembly replacement..... | 2-64 |
| ATTEN control alinement | 2-57 |
| Attenuator switch AT1 and AT2 replacement | 2-66 |
| B | |
| Battery case replacement | 2-68 |
| Battery charger circuit card A1 replacement..... | 2-83 |
| Battery charger conversion to 230 VAC operation | 2-80 |
| Battery charger cover replacement | 2-81 |
| Battery charger function | 1-16 |
| Battery charger indicator light DS1 replacement | 2-84 |
| Battery charger low voltage supply cable replacement | 2-86 |
| Battery charger power cable replacement..... | 2-85 |
| Battery charger transformer T1 replacement | 2-82 |
| Battery check capability | 1-8 |
| C | |
| Calibration | 1-2 |
| Care..... | 1-5 |
| Connector J2 replacement..... | 2-74 |
| Consolidated index of Army publications and blank forms..... | 1-1 |
| D | |
| DC power distribution | 1-7 |
| Definition of unusual terms | Glossary 1 |
| Destruction of Army electronics materiel to prevent enemy use | 1-2 |
| E | |
| Electronic components assembly replacement | 2-60 |
| Equipment characteristics, capabilities, and features..... | 1-3 |
| Equipment data | 1-3 |

INDEX (CONT)

| Subject | Page |
|---|------------|
| E (CONT) | |
| Equipment description and data | 1-3 |
| Equipment characteristics, capabilities, and features | 1-3 |
| Equipment data | 1-3 |
| Location and description of major components | 1-3 |
| Safety, care, and handling | 1-5 |
| Expendable supplies and materials list | B-1 |
| F | |
| Front panel replacement | 2-79 |
| G | |
| General information | 1-1 |
| Administrative storage | 1-2 |
| Calibration | 1-2 |
| Consolidated Index of Army publications and blank forms | 1-1 |
| Destruction of Army electronics materiel to prevent enemy use | 1-2 |
| Maintenance forms, records, and reports | 1-1 |
| Nomenclature cross-reference list | 1-2 |
| Reporting equipment Improvement recommendations (EIR) | 1-2 |
| Scope | 1-1 |
| Glossary | Glossary 1 |
| GS mode adjustment | 2-42 |
| H | |
| Handling | 1-5 |
| How to use the performance test charts | 2-2 |
| How to use this manual | II |
| I | |
| Impedance matching network A7 replacement | 2-77 |
| Index | Index 1 |
| Indicator light DS1, DS2, and DS3 replacement | 2-75 |
| Introduction | 1-1 |
| Equipment description and data | 1-3 |
| General information | 1-1 |
| Principles of operation | 1-5 |
| L | |
| Location and description of major components | 1-3 |
| LOC mode adjustment | 2-39 |

INDEX (CONT)

| Subject | M | Page |
|--|---|------|
| Maintenance | | 2-1 |
| Alinement procedures..... | | 2-39 |
| Maintenance procedures..... | | 2-59 |
| Performance test procedures | | 2-1 |
| Repair parts, special tools, TMDE, and support equipment | | 2-1 |
| Troubleshooting | | 2-34 |
| Maintenance forms, records, and reports | | 1-1 |
| Discrepancy in shipment report (DISREP) (SF361) | | 1-2 |
| Reports of maintenance and unsatisfactory equipment | | 1-1 |
| Reports of packaging and handling deficiencies | | 1-2 |
| Maintenance procedures | | 2-59 |
| Antenna jack J1 and J3 replacement..... | | 2-65 |
| A6 and A8 assembly replacement..... | | 2-62 |
| A6 circuit board assembly replacement..... | | 2-64 |
| Attenuator switch AT1 and AT2 replacement | | 2-66 |
| Battery case replacement..... | | 2-68 |
| Battery charger circuit board A1 replacement..... | | 2-83 |
| Battery charger conversion to 230 VAC operation | | 2-80 |
| Battery charger cover replacement..... | | 2-81 |
| Battery charger indicator light DS1 replacement | | 2-84 |
| Battery charger low voltage supply cable replacement..... | | 2-86 |
| Battery charger power cable replacement | | 2-85 |
| Battery charger transformer T1 replacement..... | | 2-82 |
| Connector J2 replacement | | 2-74 |
| Electronic components assembly replacement | | 2-60 |
| Front panel replacement | | 2-79 |
| General | | 2-59 |
| Impedance matching network A7 replacement | | 2-77 |
| Indicator light DS1, DS2, and DS3 replacement | | 2-75 |
| Modules A1 through A5 replacement | | 2-61 |
| Painting | | 2-80 |
| Placing in service | | 2-80 |
| Pushbutton switch S3, S4, and S5 replacement | | 2-76 |
| Pushbutton switch S8, S9, S13, S14, S19, and S20 replacement .. | | 2-71 |
| Pushbutton switch S23, S24, and S25 replacement .. | | 2-73 |
| Rotary switch S7, S11, and S17 replacement..... | | 2-78 |
| TB1 contact board replacement..... | | 2-70 |
| Toggle switch S1, S2, S6, S10, S12, S15, S16, S18, S21, and S22 replacement | | 2-72 |
| MB mode adjustment | | 2-50 |
| Modulating circuits..... | | 1-9 |
| LOC/GS modulation | | 1-10 |
| MB modulation and VOR/LOC 1020 Hz signal | | 1-13 |
| MB PWR switch ON | | 1-13 |
| VAR $\pm 10^\circ$ lamp/switch variable mode..... | | 1-12 |
| VOR modulation | | 1-11 |
| Modules A1 through A5 replacement..... | | 2-61 |

INDEX (CONT)

| Subject | Page |
|---|------|
| N | |
| Nomenclature cross-reference list..... | 1-2 |
| O | |
| Operating voltage adjustment..... | 2-52 |
| Overall operation..... | 1-6 |
| P | |
| Painting..... | 2-80 |
| Performance test charts, how to use..... | 2-2 |
| Performance test procedures..... | 2-1 |
| General..... | 2-1 |
| How to use the performance test charts..... | 2-2 |
| Performance test procedures..... | 2-4 |
| Placing in service..... | 2-80 |
| Principles of operation..... | 1-5 |
| Battery charger function..... | 1-16 |
| Battery check capability..... | 1-8 |
| DC power distribution..... | 1-7 |
| General..... | 1-5 |
| Modulating circuits..... | 1-9 |
| RF modules and RF distribution..... | 1-14 |
| VAR lamp flasher capability..... | 1-15 |
| Pushbutton switch S3, S4, and S5 replacement..... | 2-76 |
| Pushbutton switch SS, S9, S13, S14, S19, and S20 replacement..... | 2-71 |
| Pushbutton switch S23, S24, and S25 replacement..... | 2-73 |
| R | |
| References..... | A-1 |
| Repair parts..... | 2-1 |
| Repair parts, special tools, TM DE, and support equipment..... | 2-1 |
| Repair parts..... | 2-1 |
| Special tools, TM DE, and support equipment..... | 2-1 |
| Replacement: | |
| Antenna jack J1 and J3..... | 2-65 |
| A6 and A8 assembly..... | 2-62 |
| A6 circuit board assembly..... | 2-64 |
| Attenuator switch AT1 and AT2..... | 2-66 |
| Battery case..... | 2-68 |
| Battery charger circuit board A1..... | 2-83 |
| Battery charger cover..... | 2-81 |
| Battery charger indicator light DS1..... | 2-84 |
| Battery charger low voltage supply cable..... | 2-86 |
| Battery charger power cable..... | 2-85 |
| Battery charger transformer T1..... | 2-82 |
| Connector J2..... | 2-74 |

INDEX (CONT)

| Subject | Page |
|---------|------|
|---------|------|

R (CONT)

| | |
|--|------|
| Electronic components assembly..... | 2-60 |
| Front panel..... | 2-79 |
| Impedance matching network A7..... | 2-77 |
| Indicator light DS1, DS2, and DS3..... | 2-75 |
| Modules A1 through A5..... | 2-61 |
| Pushbutton switch S3, S4, and S5..... | 2-76 |
| Pushbutton switch S6, S9, S13, S14, S19, and S20..... | 2-71 |
| Pushbutton switch S23, S24, and S25..... | 2-73 |
| Rotary switch S7, S11, and S17..... | 2-78 |
| TB1 contact board..... | 2-70 |
| Toggle switch S1, S2, S6, S10, S12, S15, S16, S18, S21, and S22..... | 2-72 |
| Reporting equipment improvement recommendations (EIR)..... | 1-2 |
| RF modules and RF distribution..... | 1-14 |
| MB RF module..... | 1-15 |
| VOR, LOC, and GS RF modules..... | 1-15 |
| Rotary switch S7, S11, and S17 replacement..... | 2-78 |

S

| | |
|--|-----|
| Safety..... | 1-5 |
| Safety, care, and handling..... | 1-5 |
| Special tools, TM DE, and support equipment..... | 2-1 |

T

| | |
|---|------|
| TB1 contact board replacement..... | 2-70 |
| Toggle switch S1, S2, S6, S10, S12, S15, S16, S18, S21, and S22 replacement..... | 2-72 |
| Troubleshooting..... | 2-34 |
| General..... | 2-34 |
| Troubleshooting table..... | 2-34 |

V

| | |
|---|------|
| VAR lamp flasher capability..... | 1-15 |
| VOR bearing selector control alinement..... | 2-55 |
| VOR mode adjustment..... | 2-45 |

By Order of the Secretary of the Army:

JOHN A. WICKHAM JR.
General, United States Army
Chief of Staff

Official:

DONALD J. DELANDRO
Brigadier General, United States Army
The Adjutant General

DISTRIBUTION:

To be distributed in accordance with DA Form 12-51A literature requirements for AN/ARM-186.

* U. S. GOVERNMENT PRINTING OFFICE: 1985-505-044/20108

RECOMMENDED CHANGES TO EQUIPMENT TECHNICAL PUBLICATIONS



THEN...JOT DOWN THE DOPE ABOUT IT ON THIS FORM. CAREFULLY TEAR IT OUT, FOLD IT AND DROP IT IN THE MAIL.

SOMETHING WRONG WITH PUBLICATION

FROM: (PRINT YOUR UNIT'S COMPLETE ADDRESS)

DATE SENT

PUBLICATION NUMBER

PUBLICATION DATE

PUBLICATION TITLE

BE EXACT PIN-POINT WHERE IT IS

PAGE NO.

PARA-GRAPH

FIGURE NO.

TABLE NO.

IN THIS SPACE, TELL WHAT IS WRONG AND WHAT SHOULD BE DONE ABOUT IT.

TEAR ALONG PERFORATED LINE

PRINTED NAME, GRADE OR TITLE AND TELEPHONE NUMBER

SIGN HERE

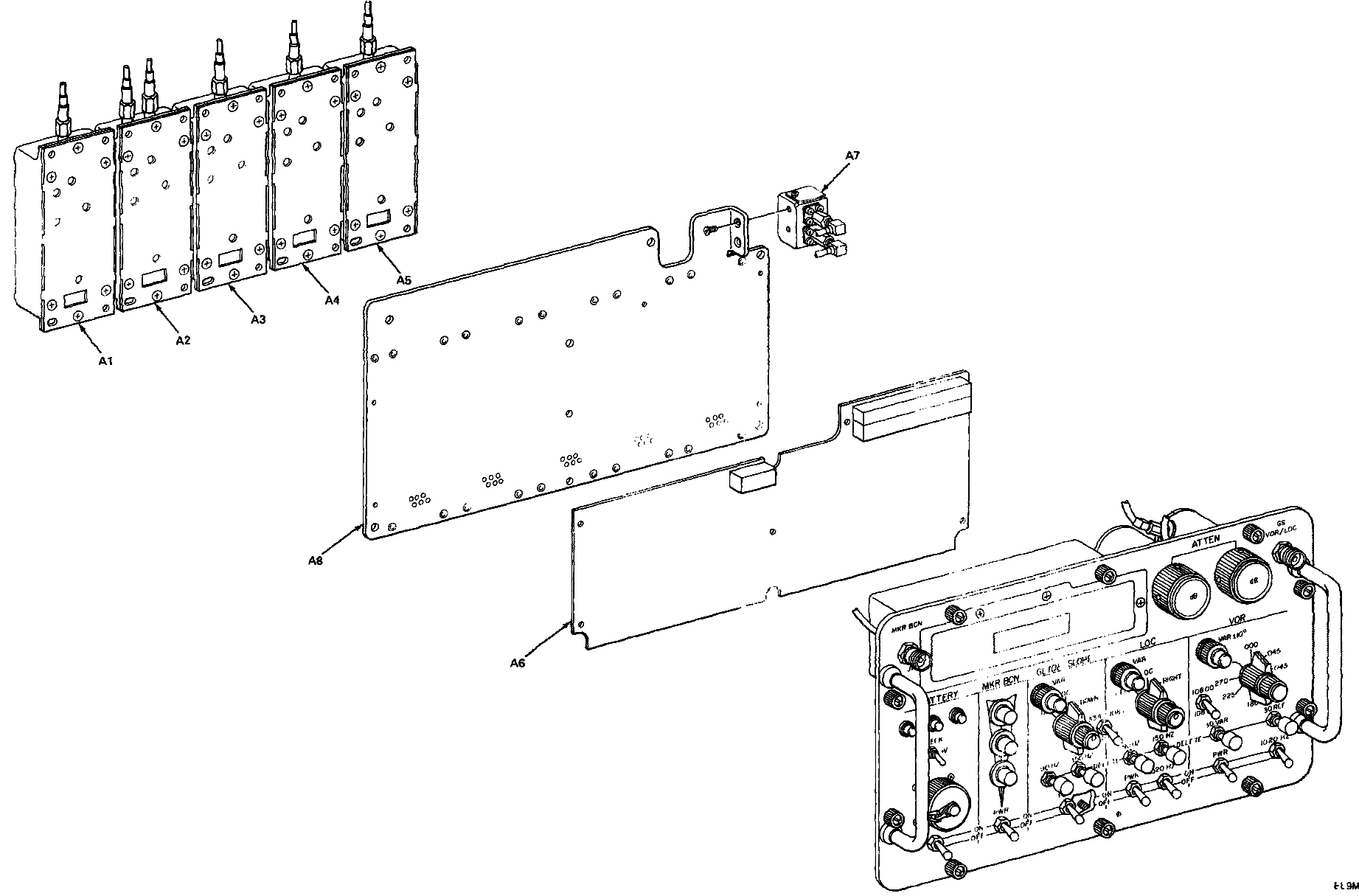

Figure FO-1. Component Location.

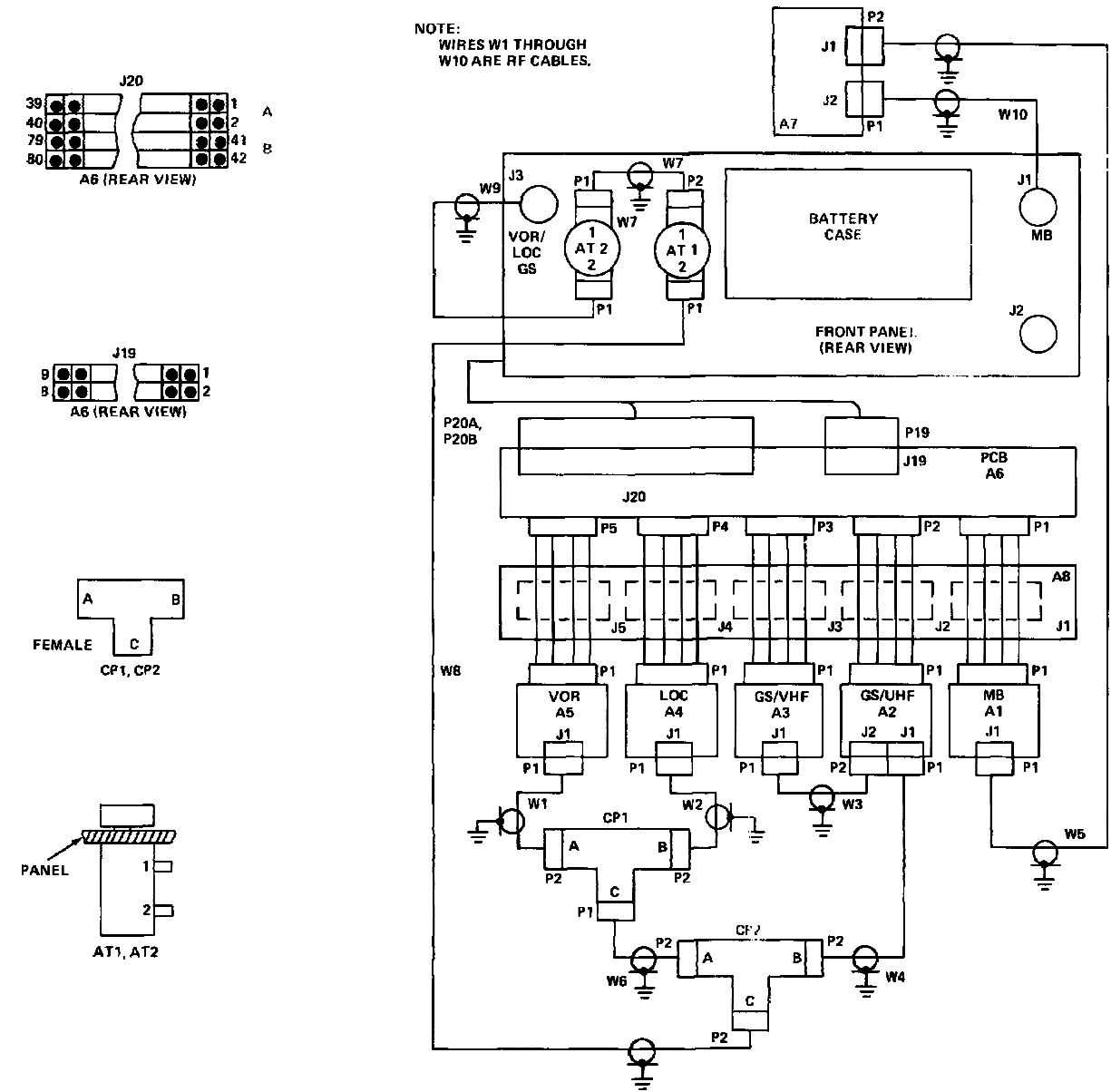

Figure FO-2. Cable Connections.

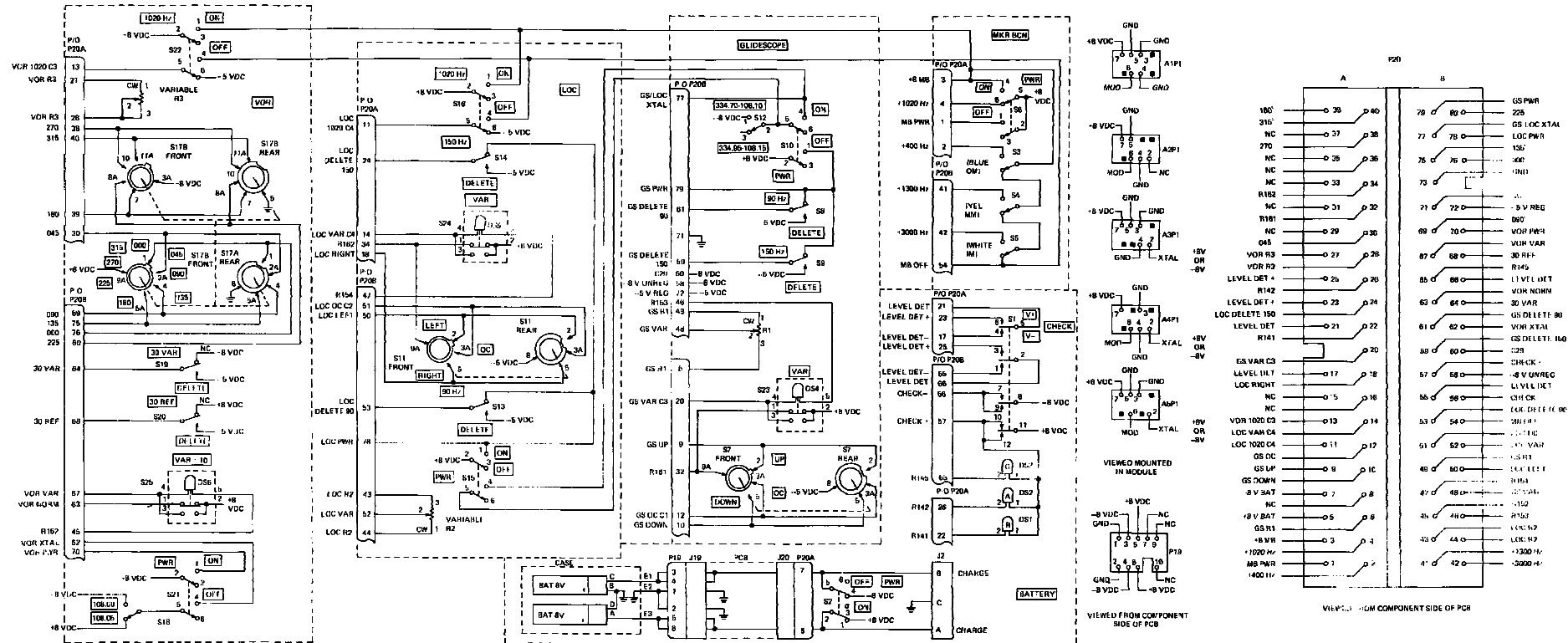

Figure FO-3. DC Power Distribution.

119A015

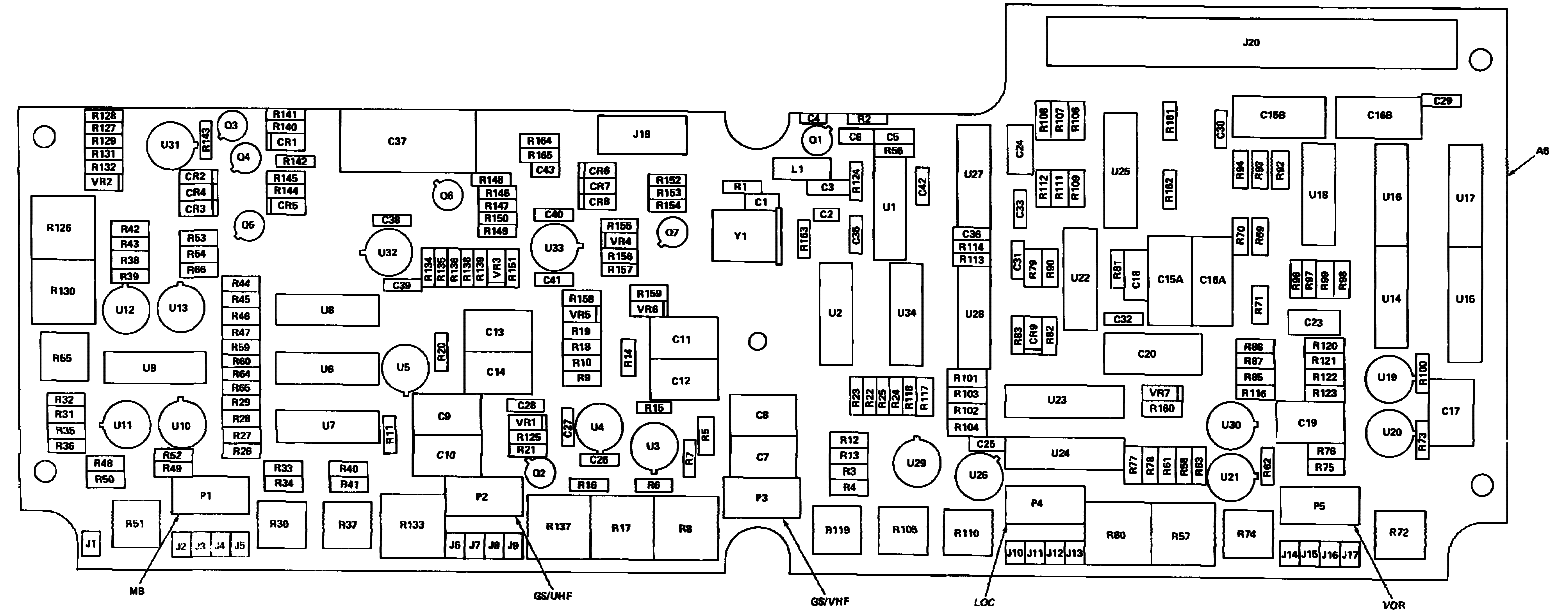
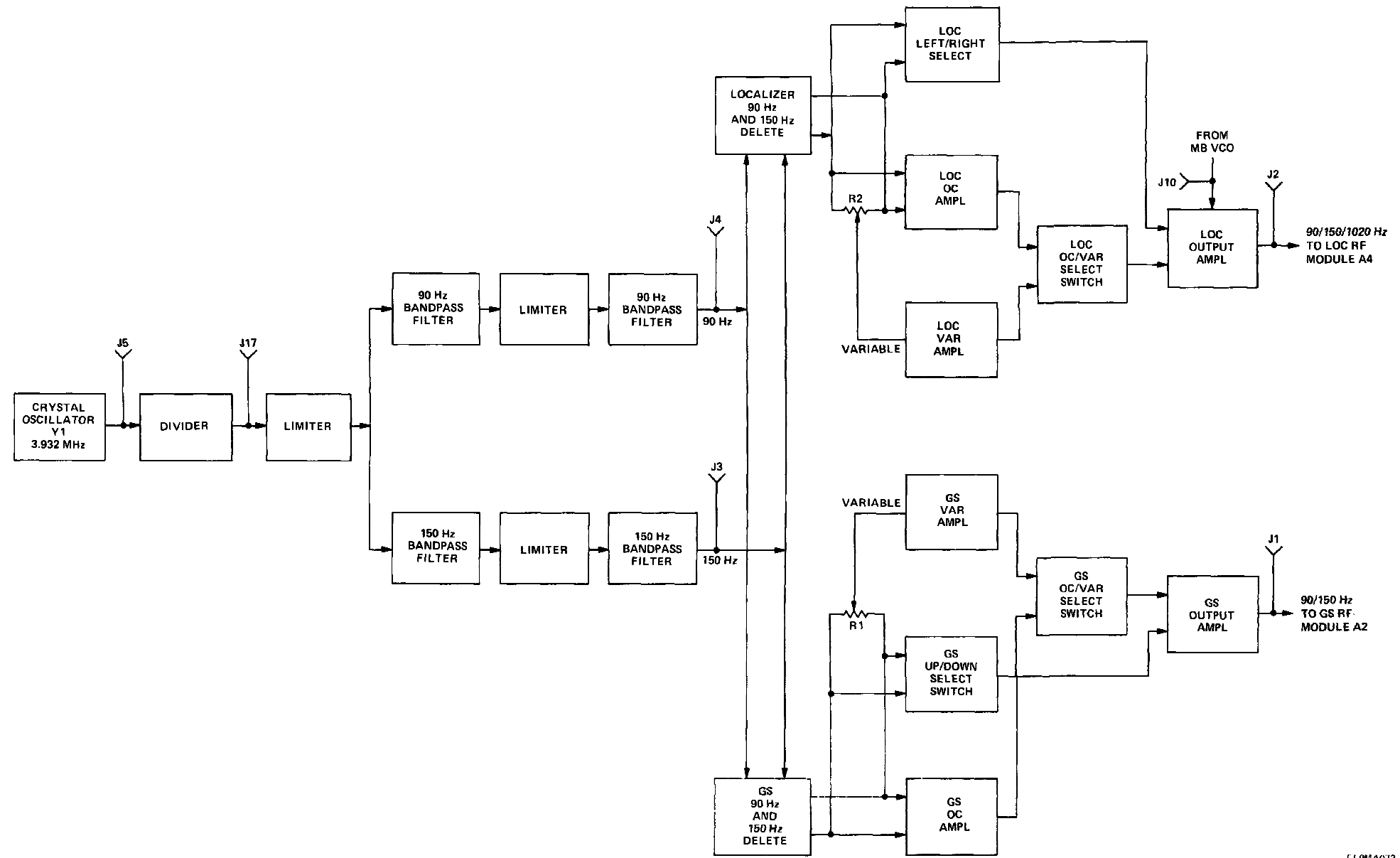

Figure FO-4. A6 Circuit Card Assembly.



FL8MA073

Figure FO-5. LOC/GS Modulation.

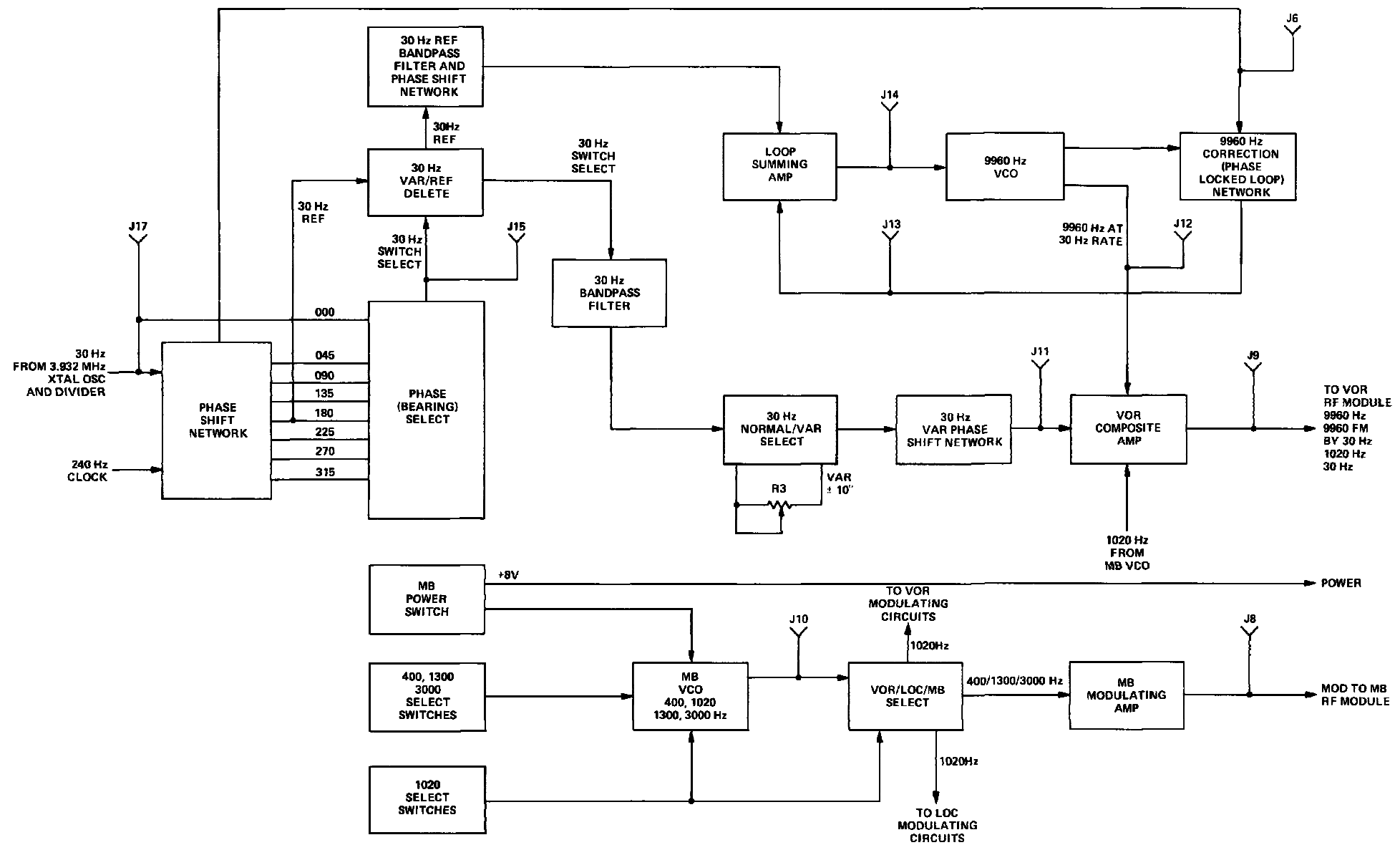

Figure FO-6. VOR and MB Modulation.

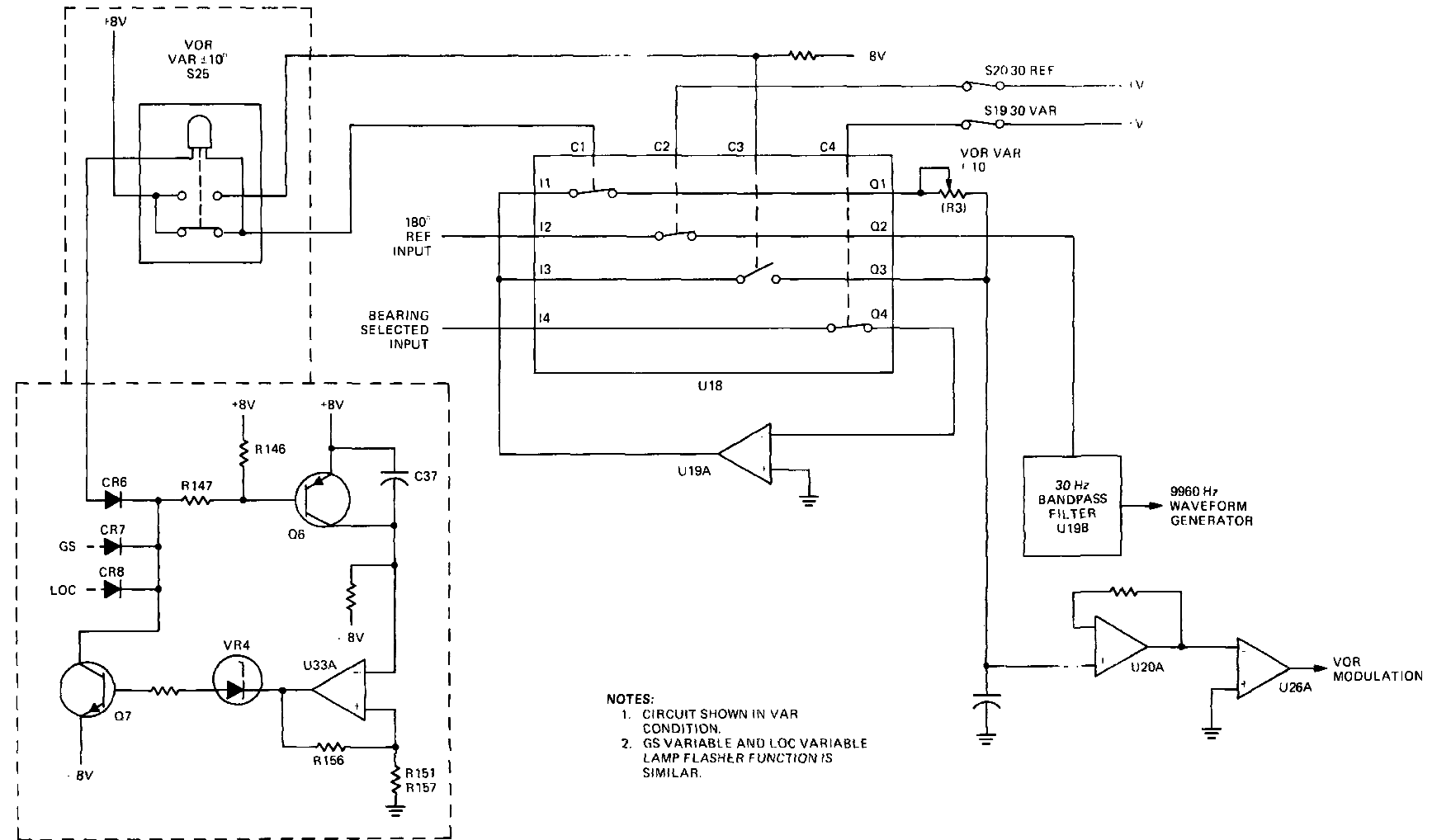
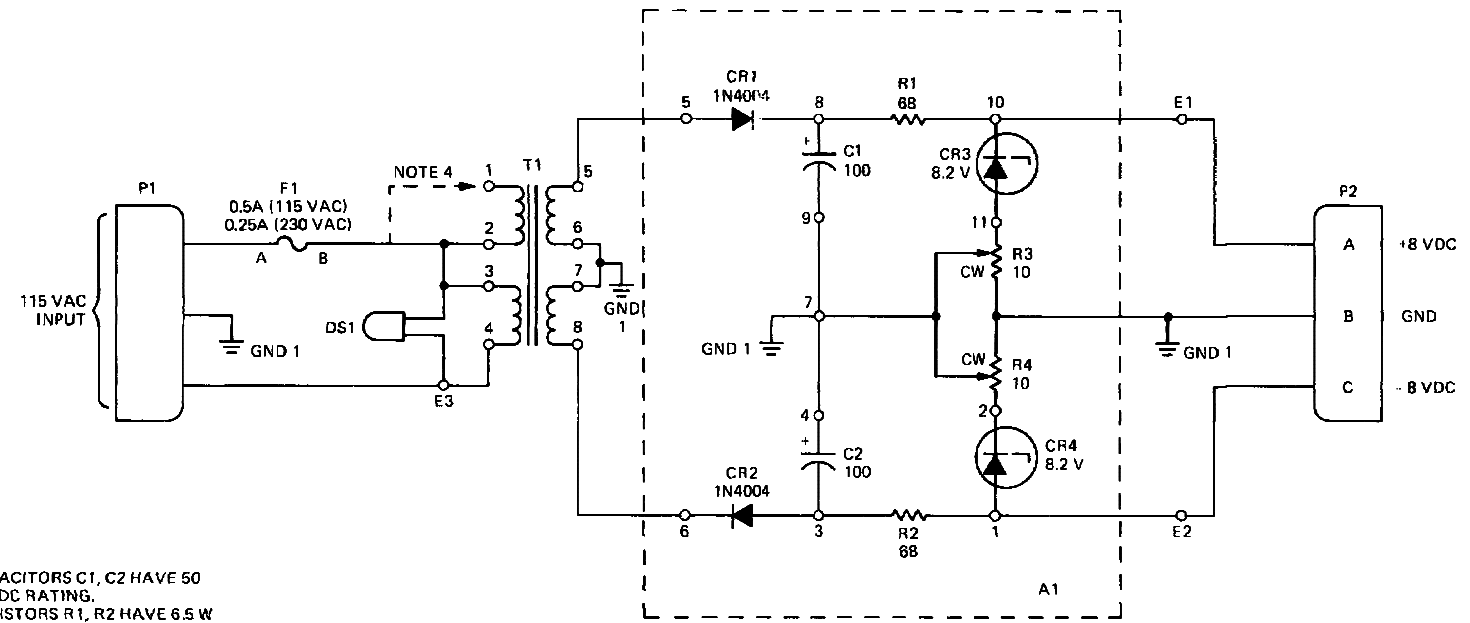

Figure FO-7. VAR Lamp Flasher Capability.



- NOTES:**
1. CAPACITORS C1, C2 HAVE 50 W VDC RATING.
 2. RESISTORS R1, R2 HAVE 6.5 W RATING.
 3. UNLESS OTHERWISE SPECIFIED, RESISTANCE VALUES ARE IN OHMS AND CAPACITANCE VALUES ARE IN MICROFARADS.
 4. T1 SHOWN CONNECTED FOR 115 VAC FOR 230 VAC OPERATION MOVE SOURCE WIRE FROM T1-2 TO T1-1.

Figure FO-8. Battery Charger Schematic Diagram.

